



Temperature controller RRV852 Duo-zone ducted systems

Duo-zone model with two zone damper outputs

Multifunctional controller used for central control of ducted HVAC systems in combination with QAX850 and QAW850 room units.

Use

Use

Comfort control of ducted HVAC systems via fan, heating, cooling and damper actuator output regulation:

- Residential apartments
- Residential single house
- Autonomous light commercial applications

Applications

The RRV852 controller is designed for central ducted HVAC systems that require easy operation by the building occupant. The MMI units that can be connected to the controller are the QAX850 master room unit and the QAW850 zone room unit. Fan, heating and/or cooling outputs combined with two damper actuator outputs control the temperature within the main day and night areas of the building. The RRV852 controller can be configured for various types of HVAC equipment. These include:

- Heating only ducted systems
- Cooling only ducted systems
- DX cooling and heating (single speed fan on heating)
- DX cooling and heating (3 speed fan)
- Air to air heat pumps
- Water to air heat pumps
- 4 pipe FCU
- 2 pipe FCU
- Single or 3 speed fan
- Duo-zone damper control or Duo-switch function option

Functions

Controller functionality is determined by the Dip switch selected application, parameter settings and mode selection via the QAX850 master room unit and QAW850 zone room units.

Duo-zone

Air conditioning system is split into two zones by the on/off control of two damper actuators. The two zones consist of the living area zone (QAX850) and the night area zone, typically the bedrooms (QAW850 or optional temperature sensor only with control/monitoring from QAX850). When both zones are selected, the average temperature between day and night zone sensors is used to control the main plant. When one of the zones is selected, its corresponding temperature sensor controls the main plant. There is “no” temperature control via the damper. The dampers isolate the zone not required. Day zone, Night zone or both zones open (day and night) is selectable by the user.

Duo-switch

Air conditioning system operates as per standard RRV851 controller corresponding application. Only the QAX850 master wall unit is connected to the RRV852 controller. Two open/close outputs (Q1 and Q2) from the RRV852 can be manually activated by the user from the QAX850. Both will turn off during System Off mode ☺ and return to their previously selected positions after resuming comfort, energy saving or auto timer mode. This feature can be used for general switching of any device complying with output technical ratings. Example: Damper actuator, control valve, relay, etc.

Note: Duo-zone does not have comfort and energy saving setpoints. The comfort symbol represents the day zone and the energy saving symbol represents the night zone. If Duo-switch is selected then comfort and energy saving mode is available as per RRV851.

**Example application:
4-pipe FCU system**

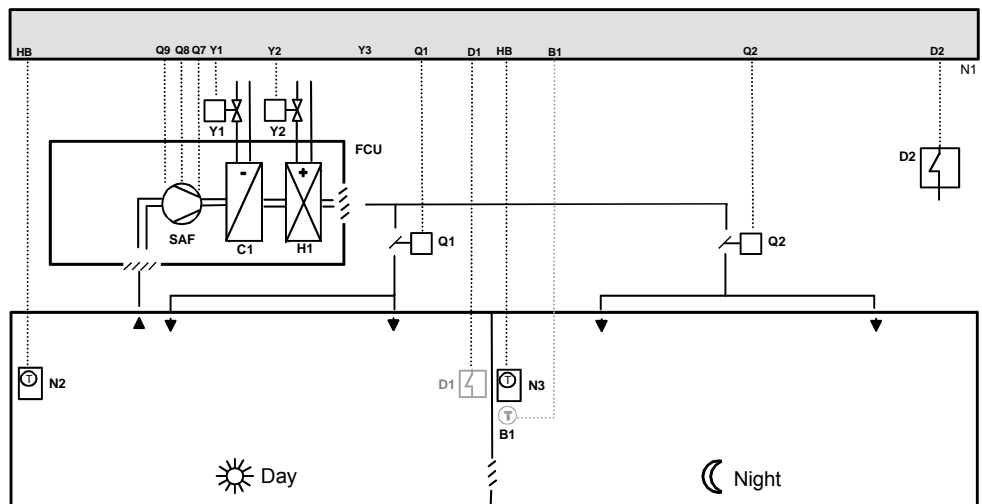

- | | | | |
|-----|----------------------------------|----|-------------------------------|
| N1 | RRV852 controller | H1 | H heating coil |
| N2 | QAX850 master room unit | C1 | Cooling coil |
| N3 | QAW850 zone room unit | D1 | Remote day zone on activation |
| FCU | Fan coil unit | D2 | Fault or emergency heat input |
| B1 | Optional night zone temp. sensor | Y1 | Cooling control valve |
| SAF | Supply air fan | Y2 | Heating control valve |
| | | Q1 | Zone damper 1 (day) |
| | | Q2 | Zone damper 2 (night) |

Type summary

ASN
RRV852

Type reference
Temperature controller

Compatible with
QAX850, QAW850, QAA32, QAH11.1

Note: The QAX850 and QAW850 for the RRV852 must be ordered separately. Any additional remote temperature sensors must also be ordered separately. Terminal covers are included in the RRV852 packaging box.

Not usable with Desigo RX range wall units.

Mechanical design

Type of unit

The RRV852 is a temperature controller providing connection of power supply, inputs/outputs, QAX850 master room unit and QAW850 zone wall unit.

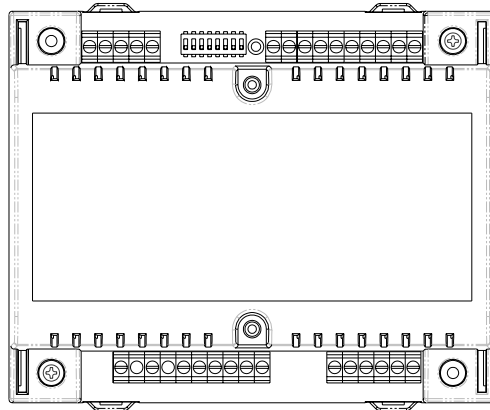

The unit consists of the following components:

- Base for DIN or screwed surface mounting
- Cable restraints
- IP30 covers (when mounted directly to wall or FCU without DIN rail)
- PCB and internal transformer
- PCB cover
- Input/output terminals
- RS485 terminals
- MMI bus terminals
- LED for power supply indication
- Configuration Dip switches

Connection terminals

Bus interface (HB+, HB-)

Low voltage power supply (12VDC) and communication transfer is supplied via two wires to the QAX850 master room unit and QAW850 zone room units from terminals HB+ and HB-. The LED on the QAX850 will flash if a communication error exists between devices for longer than 5 seconds.

RS485 (TX+, TX-)

The RS485 connections are only suitable for downloading manufacturer specific parameter sets. This is for factory use only.

Digital inputs (D1, D2)

Two digital inputs are provided. A potential free contact closed across the D1 and D_GND terminals will override to day zone, only when mode selector is set to Auto timer mode. D2 can be configured for an emergency heat enable signal or an external fault lockout signal. Either of these functions can be selected via the configuration Dip switches.

When emergency heat is selected, a potential free contact closed across the D2 and D_GND terminals will disable the primary heating output and enable the emergency

heat output. The emergency heat output will only activate when there is demand for heating. Not available on applications A2, A3, A4 and A5.

When external fault (default) is selected, a potential free contact closed across the D2 and D_GND terminals will de-activate all outputs and the standby icon on the QAX850 LCD will flash to indicate the fault. Fault will disappear after contact is opened.

Temperature sensor input (B1, M)

An NTC temperature sensor can be connected to B1 and M terminals for the following functions:

- Night zone temperature sensor: A night zone temperature sensor (QAA32) can be used instead of the QAW850 zone room unit. All night zone setpoint and mode adjustments can then be made from the QAX850 master wall unit. This is not possible if any of the below functions are selected.
- Remote room temperature sensing: The QAX850 can be used as a master control unit without using the internal temperature sensor. A separate room sensor (QAA32) can be mounted in a location more convenient for accurate temperature measuring of the day zone.
- Return air temperature sensing: A temperature sensor (QAH11.1) can be mounted in the return air path of the FCU if measuring temperature accurately in the day zone is not possible.
- 2 pipe application heating/cooling changeover: For application A8 (2 pipe FCU) a temperature sensor (QAH11.1/ARG86.3) is clamped to the water pipe in order to activate heating/cooling mode changeover.

Fan speed outputs

The RRV852 controller can be configured for a single or three speed fan. Volt-free (SPST) relay outputs Q74, Q84 and Q94 can switch loads up to AC 250V, 6(4)A. Power is supplied via terminal Q71. The low speed terminal is used when single speed fan is configured. On fan start-up the high speed will activate first for approximately 3 seconds and then resume to selected speed. During Auto fan operation the fan speeds will be activated automatically depending on demand.

For further details on auto fan speed control refer to application sheets.

Heat/cool outputs

Output Y1: Cooling or compressor output.

Output Y2: Heating or reversing valve output

Output Y3: Auxiliary output that can be configured for auxiliary heat, emergency heat, 2nd step cool or dual compressor.

Output control is two position. Three position modulating can be selected via parameter P17 for applications A1, A2 and A8 only.

Damper actuator outputs

The RRV852 controller can be configured for Duo-zone or Duo-switch functions. Volt-free (SPDT) relay outputs Q12, Q14 and Q22, Q24 can switch loads up to AC 250V, 2(0.5)A. Power is supplied via terminal Q11. The outputs are not controlled by temperature demand.

Duo-zone: Outputs are activated via manual or auto-timer selection on the QAX850 master room unit and QAW850 zone room units.

Duo-switch: Outputs are activated manually via the QAX850 master wall unit.

Configuration

Dip switches

Initial application set-up of RRV852 controller to match the connected HVAC equipment is made by the selection of dip switch positions. Dip switches are located on the top of

the RRV controller. An adhesive label is included in the RRV852 packaging box for final recording of Dip switch positions. This can be placed on the Dip switch block to avoid un-authorized changes. Further parameter settings can be made via the QAX850 master room unit if required.

Dip settings

Function	Selections	1	2	3	4	5	6	7	8
Y3 Aux. output	Auxiliary heat 20 min delay	off	off	-	-	-	-	-	
	Auxiliary heat 10 min delay	on	off	-	-	-	-	-	
	Emergency heat via D2	off	on	-	-	-	-	-	
	2 nd stage cool or compressor	on	on	-	-	-	-	-	
Fan speed	Single speed	-	-	off	-	-	-	-	
	Three speed	-	-	on	-	-	-	-	
Applic.	A1 – Heat only	-	-	-	off	off	off	off	
	A2 – Cool only	-	-	-	on	off	off	off	
	A3 – Cool / (heat 3 speed fan)	-	-	-	off	on	off	off	
	A4 – Cool / (heat 1 speed fan)	-	-	-	on	on	off	off	
	A5 – Heat pump (comp + RV)	-	-	-	off	off	on	off	
	A6 – Heat pump (heat/cool)	-	-	-	on	off	on	off	
	A7 – 4 pipe FCU	-	-	-	off	on	on	off	
	A8 – 2 pipe FCU	-	-	-	on	on	on	off	
Zone outputs	Duo-zone	-	-	-	-	-	-	-	off
	Duo-switch	-	-	-	-	-	-	-	on

Default (as delivered) positions are in bold text.

Commissioning notes

Response on start-up

When powering up, the QAX850 will display all LCD icons for approximately 3 seconds and then the software version number for another 3 seconds. It will then revert to normal display. The time segments will be blinking if time needs to be set. Set time as per operation instructions. There will be a delay before operation commences due to polling of all values.

User operation

User should not have access to dip switches or parameter settings. For Duo-zone, the user operation is via the QAX850 master wall unit and the QAW850 zone room unit. For Duo-switch function the user operation is via QAX850 only. Duo-switch operation is the same as the RRV851 standard controller plus additional manual control of two relay outputs. For user operation details refer to relevant operating instructions included in packaging box, document AP1B2726en01, AP1B2726en02 and AP1B2726en03

Sensor calibration

Generally there is no need to calibrate sensor; however the displayed room temperature on the QAX850 and QAW850 LCD can be calibrated if there is any discrepancy from the actual temperature measured with a certified thermometer. Calibration function can be accessed by pressing the ▲ and ▼ buttons simultaneously for 5 seconds. Displayed value can then be adjusted via the same buttons in 0.1K steps. Range is +/- 3K.

Commissioning

RRV852 controller should be operational after dip switch settings have been made and power is connected. Default parameter settings are based on the application selected and may be modified if required. Refer to list below. Parameters cannot be accessed if system is in off mode. Refer to installation/commissioning guide for set-up details and application sheets for default parameter values.

Set-up parameters

No	Parameter	Range
P00	Temperature scale	°C/ F°
P01	Frost protection limit in OFF mode	Off/5...8°C
P02	Over-temperature limit in OFF mode	Off/30...35°C
P03	Min. OFF time delay	0...600s
P04	Min. ON time delay	0...600s
P05	Dead band between cool and heat OFF points	0.5...6K
P06	RV ON in heat or cool mode	Heat/Cool
P07	Fan run ON after heat output turns Off	0...300s
P08	Fan run ON after cool output turns Off	0...300s
P09	FCU flush pipe time	120...600s
P11	Water temp heat mode changeover	22...32 °C
P12	Water temp cool mode changeover	10...21 °C
P13	Fan auto-speed high range	H: 80...100%
P14	Fan auto-speed medium range	M: 30...75%
P15	Fan auto-speed low range	L: 1...15%
P17	2-p or 3-p control selection	2-p/3-p
P18	P-band in heat mode /Switching differential	0.5...10K
P19	P-band in cool mode /Switching differential	0.5...10K
P20	Integration time	0...60.0 min in 0.5 min steps
P21	3-p valve actuator running time	50...300s
P23	Ventilation in dead zone	Off, H/C, C only

Mounting and installation notes

The RRV852 controller can be mounted in any orientation using the following fixing options:

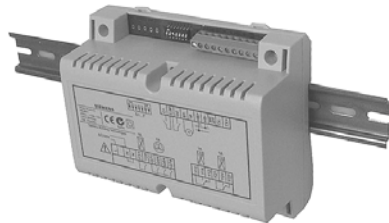

DIN Rail mounting

The housing base is designed for snap-mounting on DIN rails, type EN50022-35 x7.5 (can be released with a screwdriver).

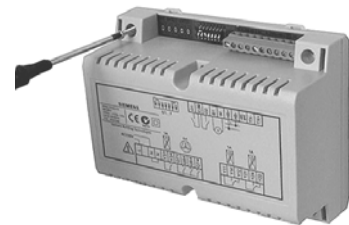

Surface mounting

There are two drill holes for screw-mounting (see "Dimensions").
Screws: Max. diameter 3.5 mm, min. length 38 mm

When mounting note the following:

- The controller should not be freely accessible after mounting.
- Ensure adequate air circulation to dissipate heat generated during operation.
- Easy access is required for service personnel
- Local installation regulations must be observed.

The mounting instructions are included in the RRV852 controller packaging.

STOP **Note!**

When not mounting within a panel, cable restraints **must** be used for all wiring to (AC 230 V) terminals. The conductors must be secured with cable ties (see diagram).

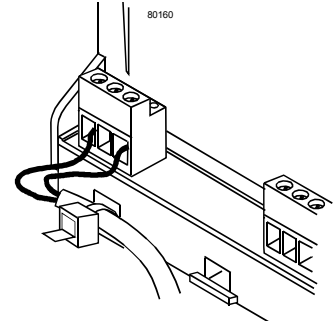

Cable restraints should be used for all wiring to avoid disconnection.

Terminal cover

Terminal covers are provided in the RRV852 packaging box. The covers include screw for fixing to controller and knock-out holes for cable entry. Covers should only be used where suitable access is restricted to authorized personnel and there is protection from ambient conditions. The covers will provide IP30 protection when surface mounted on wall or FCU.

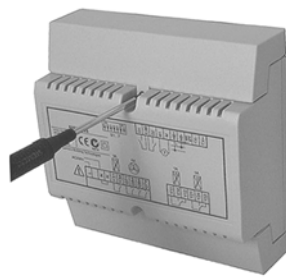

Removing the terminal cover

Technical data

Power supply L, N	Working voltage	AC 230V, +10%, -15%
	Frequency	50/60 Hz
	Power consumption	13VA
Analog input B1	Passive	NTC resistor
	Measuring range	0...49°C
Digital inputs, D1 & D2 (voltage free contacts)	Contact sensing	
	Voltage	DC 5V max.
	Current	Typically 8mA
Interface	HCC bus	Proprietary
	Baud rate	9.6 kbit/s
	Permissible cable length	Max. 60m where $A \geq 0.5\text{mm}^2$
		Max. 100m where $A \geq 1\text{mm}^2$
	Cable type	2-wire standard installation cable (unshielded)
Note: Twisted pair (unshielded) is recommended for enhanced immunity to external electromagnetic interference, for example, in the vicinity of radio transmitters or frequency inverters		
Outputs for Q7..to Q9.. (Fan outputs)	Relay contacts (potential free)	
	Switching voltage	Max. AC 250V, 6(4)A
Outputs for Q1.. to Q2..	Relay contacts (potential free)	
	Switching voltage	Max. AC 250V, 2(0.5)A
Outputs for Y...	Relay contacts (potential free)	
	Switching voltage	Max. AC 250V, 3(1)A
Protection	Protection standard to EN 60529	IP30 with terminal covers IP20 without terminal covers

Environmental conditions	Operation	IEC721-3-3 Class 3K5
	Temperature	0...+50°C
	Humidity	<85% r.h. (non condensing)
	Transport	IEC721-3-2 Class 2K3
	Temperature	-25...+65°C
	Humidity	<95% r.h. (non condensing)
Standards	Storage	IEC721-3-1 Class 1K3
	Temperature	-25...+65°C
	Humidity	<95% r.h. (non condensing)
	CE-conformity	
	EMC directive	89/336/EEC
	Immunity and Emissions	EN 60730-1, EN 50081-1, EN61000-6-2
Other features	Low voltage directive	73/23/EEC
	Electrical safety	EN 60730-1, EN 60730-2-9
	AS/NZS conformity to	
	Australian EMC Framework	Radio communication act 1992
	Radio Interference Emission	AS/NZS 4251.1
	Standard	
Software class	A to EN 60730	
Weight (excluding packaging)	0.75Kg	

Connection diagram

RRV852 terminals

B1	Signal input (ext. sensor NTC)	L, N	AC 230 V supply
M	Signal ground	Q1... Q2..	Digital outputs, AC 24..230V, 2(0.5) A
D1, D2	Digital inputs	Q7...Q84, Q94	Digital outputs, AC 24..230V, 6(4) A
D_GND	Digital ground	Y...	Digital outputs, AC 24..230V, 3(1) A
HB+ HB-	Communication bus		

RRV852 – typical connection

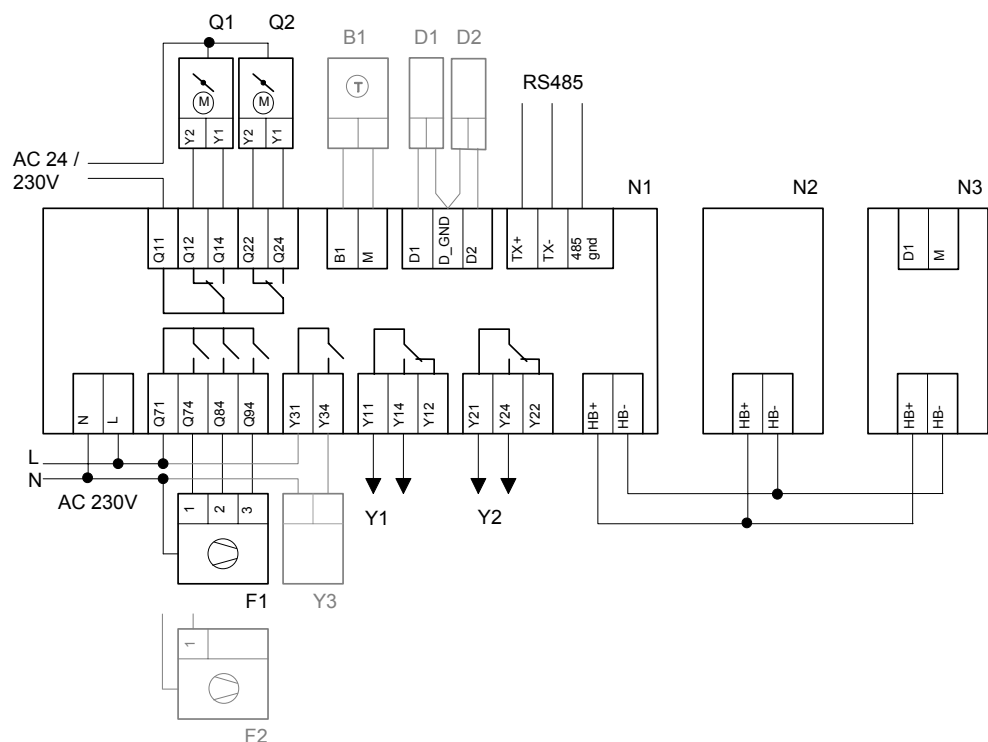

N1	RRV852 controller	Y3	Auxiliary heat, emergency heat or 2 nd stage cooling
N2	QAX850 master room unit	Q1, Q2	Damper actuator, AC 24/230V
N3	QAW850 zone room unit	F1	Three speed fan
B1	External temperature sensor (optional) or pipe changeover sensor, appl. A8	F2	Single speed fan
D1	Remote activation of day zone	RV	Reversing valve
D2	Fault or emergency heat	CR1	Compressor relay stage 1
Y1	Cooling output	CR2	Compressor relay stage 2
Y2	Heating output	Y4	Valve actuator, AC 24/ 230V

Output connections

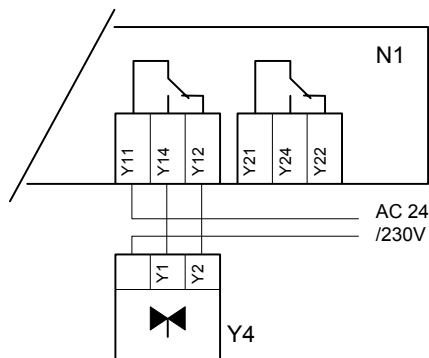

2-pipe FCU, 2-position control (appl. A8)

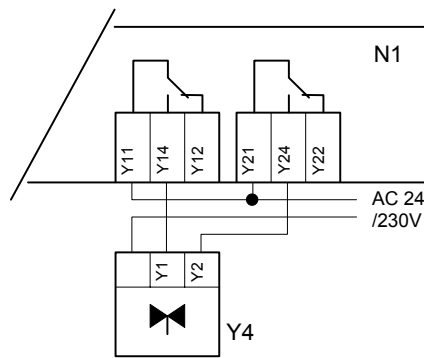

Optional 3-position control (appl. A1, A2 & A8)

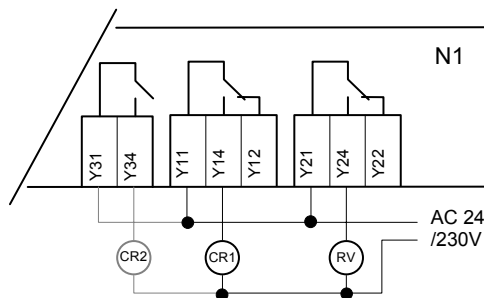

Heat pumps (appl. A5)

(For single compressor heat pumps, CR2 is not connected)

Note: Contact your local Siemens Building Technologies representatives for application specific wiring diagrams and information



Note!

- All Input and bus terminals are not protected against connection to AC 230 V.
- Observe the technical data for fan relay outputs: Max. AC 250 V, 6(4) A.
- All output cables used must satisfy the insulation requirements with regard to mains potential.
- AC 24 V outputs must be segregated from AC 250 V outputs.
- Care should be taken when cables pass through sharp metal openings, conduits or ducts.
- Double insulation on output cables is recommended.
- Local installation regulations must be observed.

Notes

Product liability

The products may only be used in building services plant and applications as described above. When using the products, all requirements specified under "Technical data" must be observed.

Supporting documentation

- QAW850 technical data, document number AP1N2721en
- QAX850 technical data, document number AP1N2722en
- QAX850 mounting instructions, document number AP1M2721
- RRV852 installation/commissioning guide, document number AP1G2726en
- RRV852 Duo-zone user operating instructions, document number AP1B2726en01 and AP1B2726en02
- RRV852 Duo-switch user operating instructions, document number AP1B2726en03
- RRV852 applications sheets

Dimensions

Without terminal covers

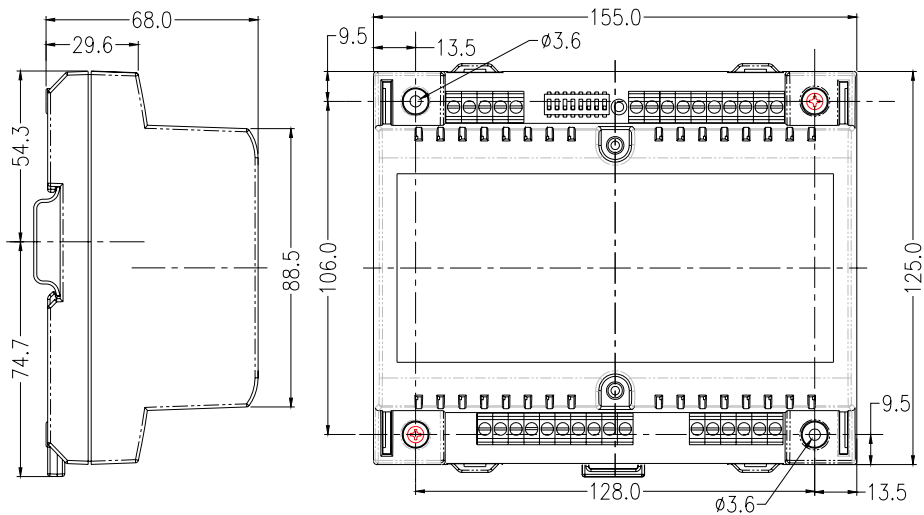

With terminal covers

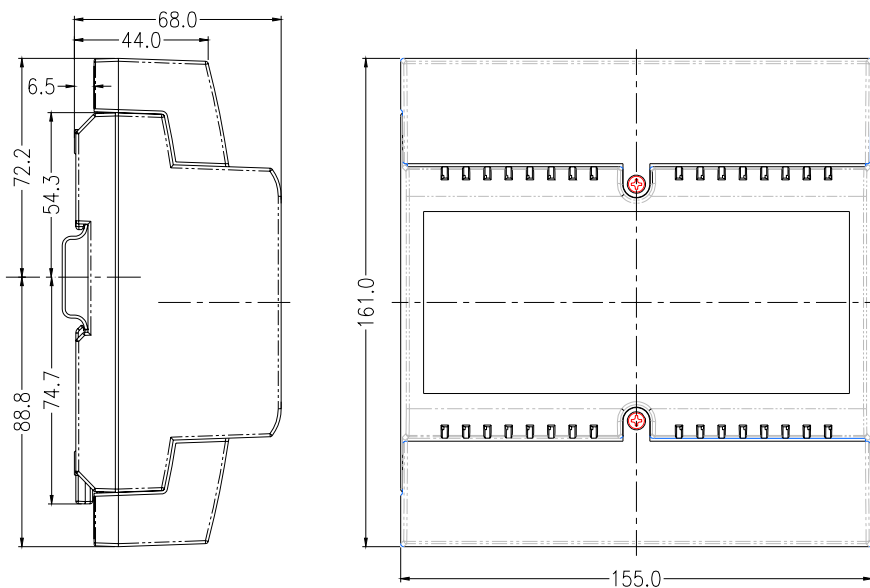

Dimensions in mm

©2005Siemens Building Technologies
HVAC Products