

Temperature controller Multi-zone ducted systems

RRV856

Multi-zone model with up to six zone outputs

Multifunctional controller used for central control of ducted HVAC systems in combination with QAX850 and QAW850 room units.

Use

Use

Comfort control of ducted HVAC systems via fan, heating, cooling and damper actuator output regulation:

- Residential apartments
- Residential single house
- Autonomous light commercial applications

Applications

The RRV856 controller is designed for central ducted HVAC systems that require easy operation by the building occupant. The MMI required to be connected to the controller is the QAX850 master room unit. Fan, heating and/or cooling outputs combined with a maximum of six damper outputs, control the temperature within each zone of the building. The RRV856 controller can be configured for various types of HVAC equipment. These include:

- Heating only ducted systems
- Cooling only ducted systems
- DX cooling and heating
- Air to air heat pumps
- Water to air heat pumps
- 4 pipe FCU
- 2 pipe FCU
- Single or 3 speed fan

Controller functionality is determined by the Dip switch selected application, parameter settings and mode selection via the QAX850 wall unit.

Multi-zone

Individual zone air conditioning control is realized by dividing the duct system into zones (2-6 zones) by the on/off control of the damper actuators. The default room unit for zone 1 is the QAX850, with QAW850 room units used for additional zones. All zone room units are linked via a DC12V two wire Bus that provides room unit power and communication.

Room units measure zone temperatures and evaluate the demand for each zone based on the corresponding zone setpoint. The zone damper opens on demand from its corresponding zone room unit and closes when there is no demand. A one minute on/off time delay and minimum 0.5K switching differential applies to the zone damper control. The (zone weighted) total system heat/cool demand is calculated by the RRV856 controller for plant heating/cooling and fan speed output control. During installation/commissioning the individual zone weight is determined by the estimated zone load (i.e.: air outlet flow rate) in comparison to other zones. Zone weight parameter P22 can be set to the following values:

- None – Local damper control only. Zone has no effect on plant heat/cool and fan speed control.
- Small – Smaller zone with low air outlet flow rate compared to other zones (i.e.: 2nd bedroom).
- Medium – Medium sized zone compared to other zones (i.e.: Master bedroom).
- Large – Large zone with higher air outlet flow rate compared to other zones (i.e.: Main living/dining area).

During installation the zone dampers should be mechanically set closed when Q1 to Q6 outputs are de-energized. On start up and after any mode change, all zone dampers will drive open if there is heat/cool demand from at least one zone or ventilation only is selected by user. Fan remains off for a period of 40 seconds to avoid over-pressure in duct. The fan then runs at high speed momentarily (3 second fan kick) before switching to low speed for 30 seconds. After this delay has elapsed, the fan will be controlled automatically based on total demand from the system. On fan start-up the zone dampers operate according to their individual zone demand and the heating/cooling output will be controlled automatically based on total heat/cool demand from system.

The following applies when a heating plus cooling application is configured:

If auto changeover of heating and cooling is selected and there is demand for both heating and cooling from the zones:

- The highest demand will take priority over the heating/cooling output
- The damper of a zone requiring cooling when system is in heating will remain off until system switches back to cooling.
- Before system switches from heating to cooling there must be cooling demand present for 30 minutes.

Note: Although system auto-changeover of heating/cooling is available, it is recommended that the user selects cool mode only in summer and heat mode only in winter.

**Example application:
4-pipe FCU system**

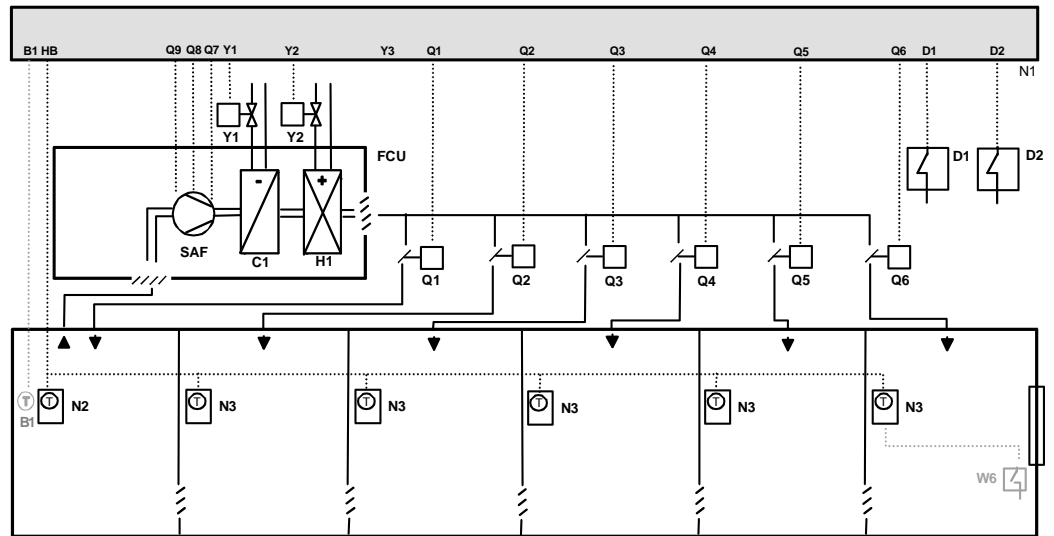

N1	RRV856 controller	H1	H eating coil
N2	QAX850 master room unit	C1	Cooling coil
N3	QAW850 zone room units	D1	Remote comfort mode input
FCU	Fan coil unit	D2	Fault or emergency heat input
B1	Optional remote temp. sensor	Y1	Cooling control valve
SAF	Supply air fan	Y2	Heating control valve
		Q1-Q6	Zone damper actuators (1-6)
		W2-W6	Optional window zone off input (Only W6 shown)

Refer to application sheets for further details on Multi-zone control.

Type summary

<i>ASN</i>	<i>Type reference</i>	<i>Compatible with</i>
RRV856	Temperature controller	QAX850, QAW850, QAA32, QAH11.1

Note

The QAX850 and the QAW850 for the RRV856 must be ordered separately. Any additional remote temperature sensors must also be ordered separately. Terminal covers are included in the RRV856 packaging box.

Not usable with Designo RX range wall units.

Mechanical design

Type of unit

The RRV856 is a temperature controller providing connection of power supply, inputs/outputs, QAW850 zone wall unit and QAX850 master wall unit.

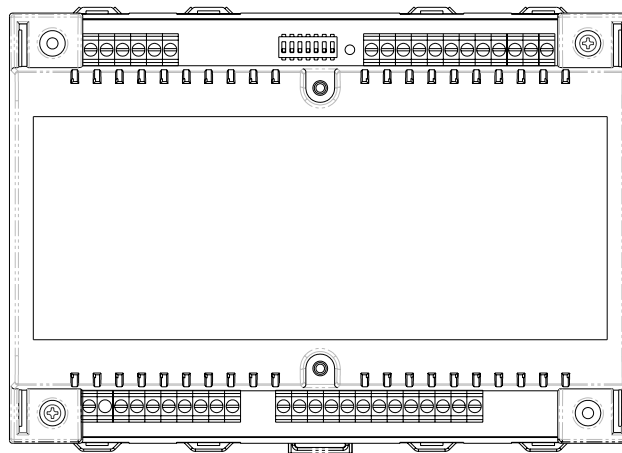

The unit consists of the following components:

- Base for DIN or screwed surface mounting

- Cable restraints
- IP30 covers (when mounted directly to wall or FCU without DIN rail)
- PCB and internal transformer
- PCB cover
- Input/output terminals
- RS485 terminals
- MMI bus terminals
- LED for power supply indication
- Configuration Dip switches

Connection terminals

MMI (HB+, HB-)	Low voltage power supply (12VDC) and communication transfer is supplied via two wires to the QAX850 and QAW850 wall units from terminals HB+ and HB-. The LED on the QAX850 will flash if a communication error exists between devices for longer than 5 seconds.
RS485 (TX+, TX-)	The RS485 connections are only suitable for downloading manufacturer specific parameter sets. This is for factory use only.
Digital inputs (D1, D2)	<p>Two digital inputs are provided. A potential free contact closed across the D1 and D_GND terminals will override to comfort mode, only when mode selector is set to Auto timer mode. D2 can be configured for an emergency heat enable signal or an external fault lockout signal. Either of these functions can be selected via the configuration Dip switches.</p> <p>When emergency heat is selected, a potential free contact closed across the D2 and D_GND terminals will disable the primary heating output and enable the emergency heat output. The emergency heat output will only activate when there is demand for heating. Not available on applications A2, A3, A4 and A5.</p> <p>When external fault (default) is selected, a potential free contact closed across the D2 and D_GND terminals will de-activate all outputs and the standby icon on the QAX850 LCD will flash to indicate the fault. Fault will disappear after contact is opened.</p>
Temperature sensor input (B1, M)	<p>An NTC temperature sensor can be connected to B1 and M terminals for the following functions:</p> <ul style="list-style-type: none"> • Remote room temperature sensing: The QAX850 can be used as a master control unit without using the internal temperature sensor. A separate room sensor (QAA32) can be mounted in a location more convenient for accurate zone 1 temperature measuring. • 2 pipe application heating/cooling changeover: For application A8 (2 pipe FCU) a temperature sensor (QAH11.1/ARG86.3) is clamped to the water pipe in order to activate heating/cooling mode changeover.
Fan speed outputs	The RRV856 controller can be configured for a single or three speed fan. Volt-free (SPST) relay outputs Q74, Q84 and Q94 can switch loads up to AC 250V, 6(4) A. Power is supplied via terminal Q71. The low speed terminal is used when single speed fan is configured. On fan start-up the high speed will activate first for approximately 3 seconds and then resume to selected speed. During Auto fan operation the fan speeds will be activated automatically depending on total demand from all zones and fan speed switching parameter settings. Single speed fan should only be selected if another form of fan speed or duct static pressure control is utilized.

Heat/cool outputs

Output Y1: Cooling or compressor output.

Output Y2: Heating or reversing valve output

Output Y3: Auxiliary output that can be configured for auxiliary heat, emergency heat, 2nd step cool or dual compressor.

Output control is two position. Three position modulating can be selected via parameter P17 for applications A1, A2 and A8 only.

Damper actuator outputs

The RRV856 has six 2 position zone damper actuator outputs. Volt-free (SPDT) relay outputs Q1, Q2, Q3, Q4, Q5 and Q6 can switch loads up to 250VAC, 0.5A inductive. Power is supplied via terminal Q11. The outputs will activate when there is demand for heating or cooling within the corresponding zone. All zone outputs will be open when in ventilation mode as selected via QAX850.

Configuration

Dip switches

Initial application set-up of RRV856 controller to match the connected HVAC equipment is made by the selection of dip switch positions. Dip switches are located on the top of the RRV controller. An adhesive label is included in RRV856 packaging box for final recording of Dip switch positions. This can be placed on the Dip switch block to avoid un-authorized changes. Further parameter settings can be made via the QAX850 if required.

Dip settings

Function	Selections	1	2	3	4	5	6	7
Y3 Aux. output	Auxiliary heat 20 min delay	off	off	-	-	-	-	-
	Auxiliary heat 10 min delay	on	off	-	-	-	-	-
	Emergency heat via D2	off	on	-	-	-	-	-
	2 nd stage cool or compressor	on	on	-	-	-	-	-
Fan speed	Single speed	-	-	off	-	-	-	-
	Three speed	-	-	on	-	-	-	-
Applic.	A1 - Heat only	-	-	-	off	off	off	off
	A2 - Cool only	-	-	-	on	off	off	off
	A3 - Cool / Heat (HHW)	-	-	-	off	on	off	off
	A4 - Cool / Heat (EDH)	-	-	-	on	on	off	off
	A5 - Heat pump (comp + RV)	-	-	-	off	off	on	off
	A6 - Heat pump (heat/cool)	-	-	-	on	off	on	off
	A7 - 4 pipe FCU	-	-	-	off	on	on	off
	A8 - 2 pipe FCU	-	-	-	on	on	on	off

Default (as delivered) positions are in bold text.

Commissioning notes

Response on start-up

When powering up, the QAX850 will display all LCD icons for approximately 3 seconds and then the software version number for another 3 seconds. It will then revert to normal display. The time segments will be blinking if time needs to be set. Set time as per operation instructions. There will be a delay before operation commences due to polling of all values and Multi-zone system start-up sequence.

User operation

User should not have access to dip switches or parameter settings. User operation is via the QAX850 master wall unit and the QAW850 zone wall unit. For user operation details

refer to operating instructions included in packaging box, document AP1B2727en01 and AP1B2727en02.

Sensor calibration

Generally there is no need to calibrate sensor; however the displayed room temperature on the QAX850 and QAW850 LCD can be calibrated if there is any discrepancy from the actual temperature measured with a certified thermometer. Calibration function can be accessed by pressing the ▲ and ▼ buttons simultaneously for 5 seconds. Displayed value can then be adjusted via the same buttons in 0.1K steps. Range is +/- 3K.

Commissioning

RRV856 controller should be operational after dip switch settings have been made and power is connected. Default parameter settings are based on the application selected and may be modified if required. Refer to list below. Only parameters relevant to selected application are displayed on the QAX850. Parameters cannot be accessed if system is in off mode. Refer to installation/commissioning guide for set-up details and application sheets for default parameter values.

Set-up parameters

No	Parameter	Range
P00	Temperature scale	°C/ F°
P01	Frost protection limit in OFF mode	Off/5...8°C
P02	Over-temperature limit in OFF mode	Off/30...35°C
P03	Min. OFF time delay	0...600s
P04	Min. ON time delay	0...600s
P05	Dead band between cool and heat OFF points	0.5...6K
P06	RV ON in heat or cool mode	Heat/Cool
P07	Fan run ON after heat output turns Off	0...300s
P08	Fan run ON after cool output turns Off	0...300s
P09	FCU flush pipe time	120...600s
P10	Zone heat/cool inhibit	Heat/Cool/No
P11	Water temp. heat mode changeover	22...32 °C
P12	Water temp. cool mode changeover	10...21 °C
P13	Fan auto-speed high range	H:80...100%
P14	Fan auto-speed medium range	M:30...75%
P15	Fan auto-speed low range	L: 1...15%
P16	Window contact	NO/NC
P17	2-p or 3-p control selection	2-p/3-p
P18	Heating demand P-band/Switching differential	0.5...10K
P19	Cooling demand P-band/Switching differential	0.5...10K
P20	Demand Integration time	0...60.0 min in 0.5 min steps
P21	3-p valve actuator running time	50...300s
P22	Zone capacity weight	None Small Medium Large
P23	Ventilation in dead zone	Off, H/C, C only

Mounting and installation notes

The RRV856 controller can be mounted in any orientation using the following fixing options:

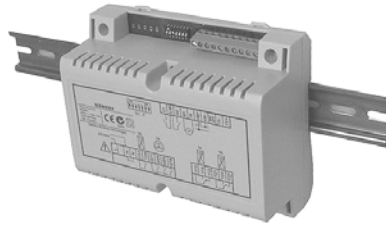

DIN Rail mounting

The housing base is designed for snap-mounting on DIN rails, type EN50022-35 x7.5 (can be released with a screwdriver).

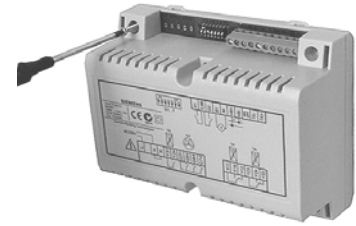

Surface mounting

There are two drill holes for screw-mounting (see "Dimensions").

Screws: Max. diameter 3.5 mm, min. length 38 mm

When mounting note the following:

- The controller should not be freely accessible after mounting.
- Ensure adequate air circulation to dissipate heat generated during operation.
- Easy access is required for service personnel
- Local installation regulations must be observed.

The mounting instructions are included in the RRV856 controller packaging.

Note!

When not mounting within a panel, cable restraints **must** be used for all wiring to (AC 230V) terminals. The conductors must be secured with cable ties (see diagram).

Cable restraints should be used for all wiring to avoid disconnection.

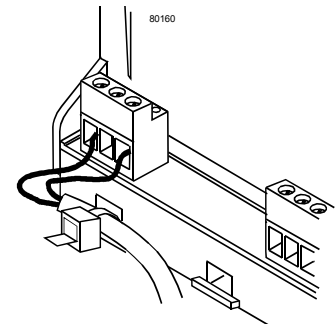

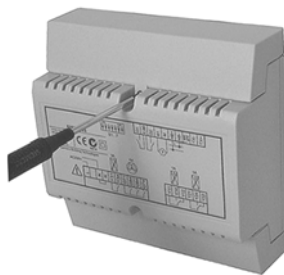

Terminal cover

Terminal covers are provided in the RRV856 packaging box. The covers include screw for fixing to controller and knock-out holes for cable entry. Covers should only be used where suitable access is restricted to authorized personnel and there is protection from ambient conditions. The covers will provide IP30 protection when surface mounted on wall or FCU.



Removing the terminal cover

Technical data

Power supply L, N	Working voltage	AC 230V, +10%, -15%	
	Frequency	50/60 Hz	
	Power consumption	15VA	
Analog input B1	Passive	NTC resistor	
	Measuring range	0...49°C	
Digital inputs, D1 & D2 (voltage free contacts)	Contact sensing		
	Voltage	DC 5V max.	
	Current	Typically 8mA	
Interface	HCC bus	Proprietary	
	Baud rate	9.6 kbit/s	
	Permissible cable length		Max. 60m where $A \geq 0.5\text{mm}^2$
			Max. 100m where $A \geq 1\text{mm}^2$
	Bus topology	Free configuration. Ring, star etc.	
	Cable type	2-wire standard installation cable (unshielded)	
	Note: Twisted pair (unshielded) is recommended for enhanced immunity to external electromagnetic interference, for example, in the vicinity of radio transmitters or frequency inverters		
Outputs for Q7...Q9 (Fan outputs)	Relay contacts (potential free)		
	Switching voltage	Max. AC 250V, 6(4)A	
Outputs for Q1...Q6 (damper actuators)	Relay contacts (potential free)		
	Switching voltage	Max. AC 250V, (0.5)A inductive	
Outputs for Y...	Relay contacts (potential free)		
	Switching voltage	Max. AC 250V, 3(1)A	
Protection	Protection standard to EN 60529	IP30 with terminal covers	
		IP20 without terminal covers	
Environmental conditions	Operation	IEC721-3-3 Class 3K5	
	Temperature	0...+50°C	
	Humidity	<85% r.h. (non condensing)	
	Transport	IEC721-3-2 Class 2K3	
	Temperature	-25...+65°C	
	Humidity	<95% r.h. (non condensing)	
	Storage	IEC721-3-1 Class 1K3	
	Temperature	-25...+65°C	
Standards	Humidity	<95% r.h. (non condensing)	
	 -conformity		
	EMC directive	89/336/EEC	
	Immunity and Emissions	EN 60730-1, EN 50081-1, EN61000-6-2	
	Low voltage directive	73/23/EEC	
	Electrical safety	EN 60730-1, EN 60730-2-9	
	 conformity to		
	Australian EMC Framework Radio Interference Emission Standard	Radio communication act 1992 AS/NZS 4251.1	
Others features	Software class	A to EN 60730	
	Weight (excluding packaging)	1.065Kg	

Connection diagrams

RRV856 terminals

B1	Signal input (ext. sensor NTC)	HB+, HB-	Communication bus
M	Signal ground	L, N	AC 230V supply
D1, D2	Digital inputs	Q7..., Q84, Q94	Digital outputs, AC24...230V, 6(4) A
D_GND	Digital ground	Q1..., Q6...	Digital outputs, AC24...230V, (0.5) A
		Y...	Digital outputs, AC24...230V, 3(1) A

RRV856 – typical connection

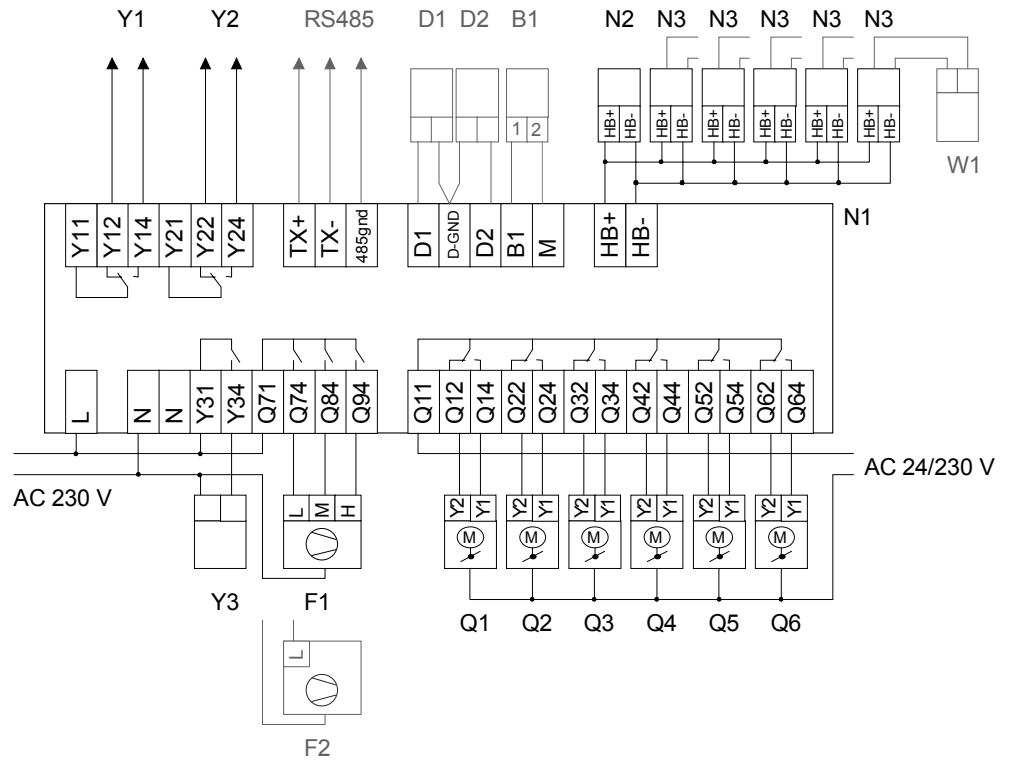

N1	RRV856 controller	Y3	Auxiliary heat, emergency heat or 2 nd stage cooling
N2	QAX850 master room unit	W1	Optional window zone off input
N3	QAW850 zone room unit	F1	Three speed fan
B1	External zone 1 temp sensor (optional) or pipe changeover sensor, appl. A8	F2	Single speed fan
D1	Remote activation of comfort mode	RV	Reversing valve
D2	Fault or emergency heat	CR1	Compressor relay stage 1
Y1	Cooling output	CR2	Compressor relay stage 2
Y2	Heating output	Y4	Valve actuator, AC24/ 230V

Output connections

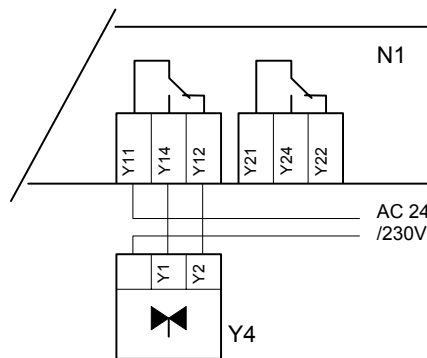

2-pipe FCU, 2-position control (appl. A8)

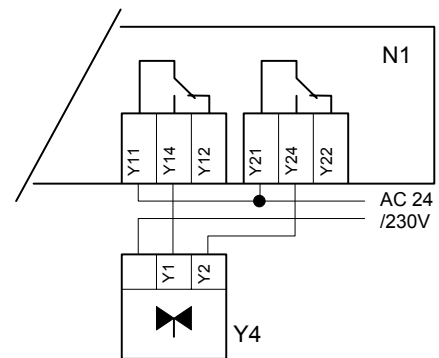

Optional 3-position control (appl. A1, A2 & A8)

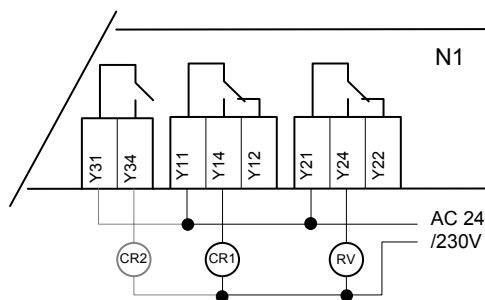

(For single compressor heat pumps, CR2 is not connected)

Heat pumps (appl. A5)

Note: Contact your local Siemens Building Technologies representatives for application specific wiring diagrams and information



Note!

- **All Input and bus terminals are not protected against connection to AC 230 V.**
- **Observe the technical data for fan relay outputs: Max. AC 250 V, 6(4) A.**
- **All output cables used must satisfy the insulation requirements with regard to mains potential.**
- **AC 24 V outputs must be segregated from AC 250 V outputs.**
- **Care should be taken when cables pass through sharp metal openings, conduits or ducts.**
- **Double insulation on output cables is recommended.**
- **Local installation regulations must be observed.**

Notes

Product liability

The products may only be used in building services plant and applications as described above. When using the products, all requirements specified under "Technical data" must be observed.

Supporting documentation

- QAX850 technical data, document number AP1N2722en
- QAW850 technical data, document number AP1N2721en
- QAX850 mounting instructions, document number AP1M2721
- RRV856 installation/commissioning guide, document number AP1G2727en
- RRV856 user operating instructions, document number AP1B2727en01 and AP1B2727en02
- RRV856 applications sheets

Dimensions

Without terminal covers

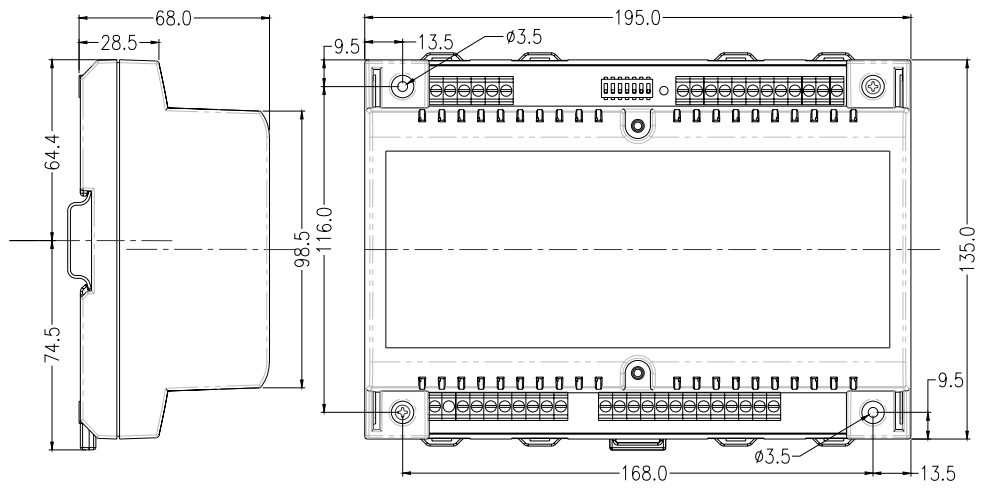

With terminal covers

