

2-port valves MVI421.15 to MVI421.25

3-port valves MXI421.15 to MXI421.25

2-Port and 3-Port Zone Valves, PN16

MVI421...
MXI421...

Max. permissible pressure 2000 kPa

-
- **Operating voltage AC 230 V, 2-position control signal**
 - **Spring return**
 - **Positioning force 105 N**
 - **Direct mounting with union nut, no tools required**
 - **Ergonomically designed manual adjuster**
 - **Auxiliary switch, type ASC2.1/18 (optional)**
 - **Hot-pressed brass valve body**
 - **DN 15, DN 20 and DN 25**
 - **$k_{vs} = 2...5 \text{ m}^3/\text{h}$**
 - **Internally threaded connections Rp... to ISO 7/1**

Use

- In ventilation and air conditioning systems for water-side terminal unit control in closed circuits, e.g. induction units, fan coil units, small re-heaters and small re-coolers, for use in
 - 2-pipe systems with 1 heat exchanger for heating and cooling
 - 4-pipe systems with 2 separate heat exchangers for heating and cooling
- In closed-circuit zone heating systems, e.g.
 - Separate floors in a building
 - Apartments
 - Individual rooms
 - Floor heating

Type summary

DN	Connection	k_{vs} [m ³ /h]	MVI421... (2-port)	Δp_s [kPa]	MXI421... (3-port)	Δp_{max} [kPa]	Actuator Positioning force
15	Rp 1/2"	2.0	MVI421.15	300	MXI421.15	300 ¹⁾	105 N
20	Rp 3/4"	3.5	MVI421.20	300	MXI421.20		
25	Rp 1"	5.0	MVI421.25	300	MXI421.25		

- ¹⁾ Where Δp_{max} is above 100 kPa, there is an increased risk of noise and erosion on the seat and plug
- k_{vs} = Nominal flow rate of cold water (5 to 30 °C) through the fully open valve (H_{100}), by a differential pressure of 100 kPa (1 bar)
- Δp_s = Maximum permissible differential pressure at which the motorized valve will close securely against the pressure (close off pressure)
- Δp_{max} = Maximum permissible differential pressure across the valve's control path, valid for the entire actuating range of the motorized valve

Accessories

Type code	Designation	Switching point	Contact rating
ASC2.1/18	Auxiliary switch on / off	At approx. 50 % stroke	Max. AC 250 V, 3 (2) A

Thermostats

Type code	Thermostat compatible to MVI421... / MXI421...
RAB...	RAB10; RAB10.1; RAB20; RAB20.1; RAB30; RAB30.1; RAB40.1
RCC....	RCC10; RCC20; RCC20.1; RCC30
RDF...	RDF10; RDF10.1; RDF10.2; RDF20; RDF30

Ordering

When ordering, please specify the quantity, product name and type code.

Example 10 3-port zone valves, type MXI421.25

Delivery

The valves and actuators are packed together, the auxiliary switches will be packed separate.

Function

The zone valves are closed when de-energised. An on/off controller (thermostat) is required to drive the motorised valve actuators. If the temperature of the medium deviates from the set point, the controller delivers a control signal that drives the actuators, causing the valve to open. When the temperature of the medium reaches the set point the control signal is cut off and the valve closes.

If required the M...I421... valve can be added with an auxiliary switch ASC2.1/18.

Accessories

ASC2.1/18 auxiliary switch

The optional auxiliary switch can be fitted to the actuator with two screws.

It switches at a stroke of approx. 50 %.

0 ... 50 % : Q11 → Q12 closed Q11 → Q14 open

50 % ... 1 : Q11 → Q12 open Q11 → Q14 closed

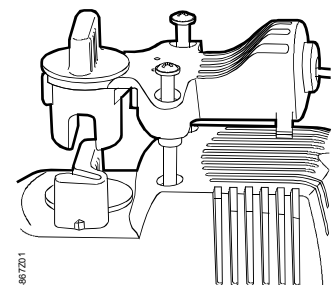

See «Technical data» for further information on the auxiliary switch.

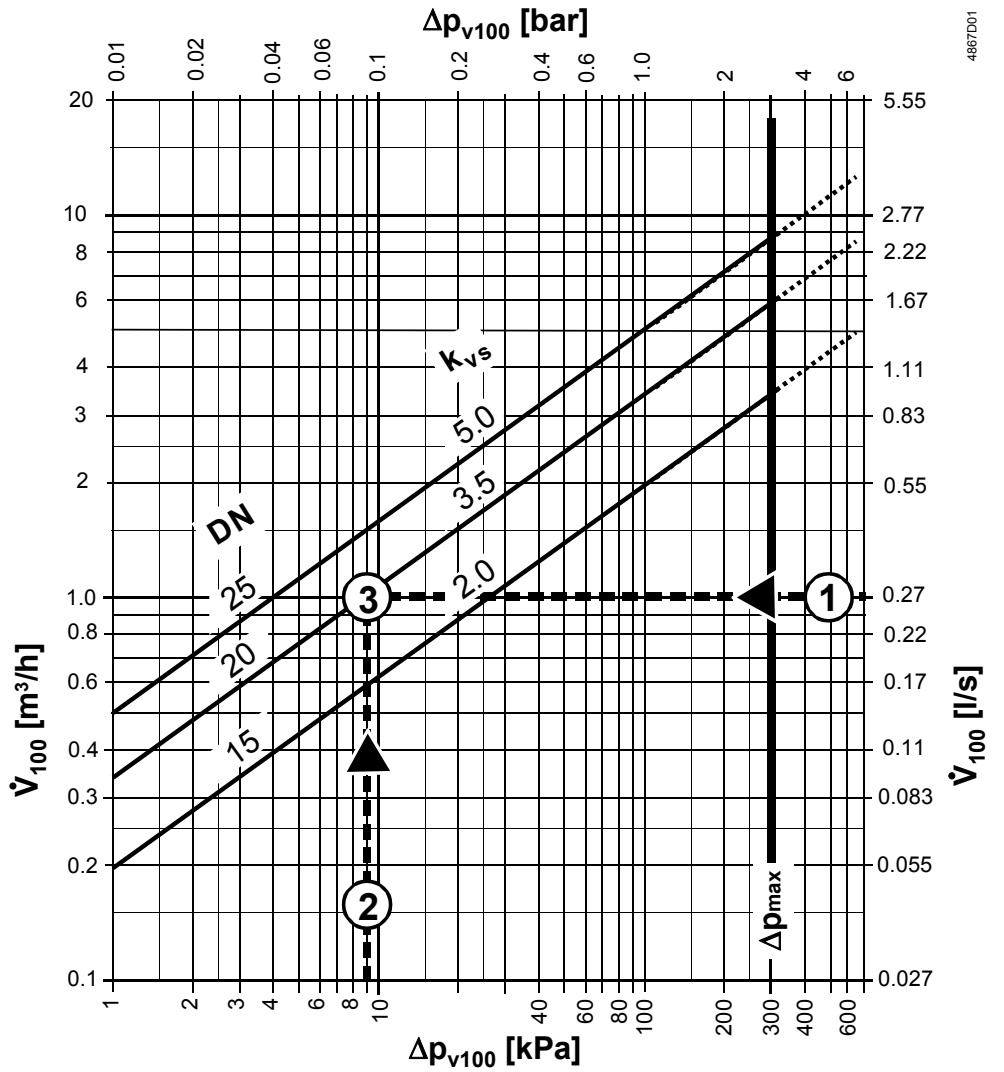

Example:

- 1 \dot{V}_{100} = 0.27 l/s
- 2 Δp_{v100} = 9 kPa
- 3 k_{vs} value required = 3.5 m³/h

Δp_{v100} = Differential pressure across the fully opened valve and the valve's control path A → AB (2-port valves), AB → A (3-port diverting valves) or A → AB (3-port mixing valves) by a volume flow \dot{V}_{100}

\dot{V}_{100} = Volume flow through the fully open valve (H_{100})

Δp_{max} = Maximum permissible differential pressure across the valve's control path, valid for the entire actuating range of the motorised valve

100 kPa = 1 bar ≈ 10 mWG



1 m³/h = 0.278 l/s water at 20 °C

Engineering notes

See also «Mounting notes» and «Commissioning notes».

The valves should preferably be installed in the return, where the seals are exposed to lower temperatures. It is not allowed to put a shut off at the bypass port B.

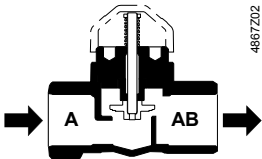
Recommendation A strainer should be fitted upstream of the valve. This increases reliability.

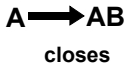
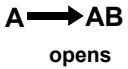
Valve construction	Valve series	Valve flow in control mode		Valve stem	
		Inlet A	Outlet AB	Retracted	Extended
	VV...46... 	Variable	Variable		

Warning The direction of flow **MUST** be as indicated by the arrow, from A → AB.

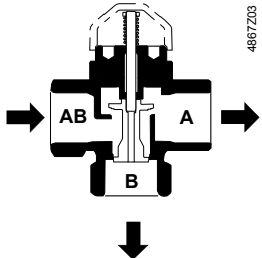
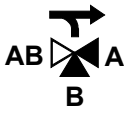
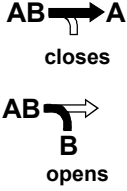
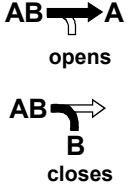
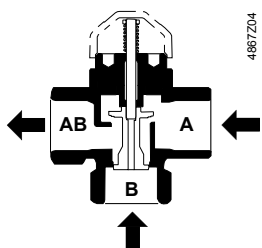
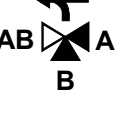
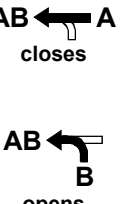
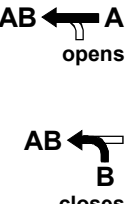
Valve construction	Valve series	Valve flow in control mode			Valve stem	
		AB	A	B	Retracted	Extended
	VX...46... 	Inlet: constant	Outlet: variable	Outlet: variable		
	VX...46... 	Outlet: constant	Inlet: variable	Inlet: variable		

Warning The direction of flow **MUST** be as indicated by the arrow, from AB → A and AB → B (diverting valves) or A → AB and B → AB (mixing valves).

Mounting notes

Orientation

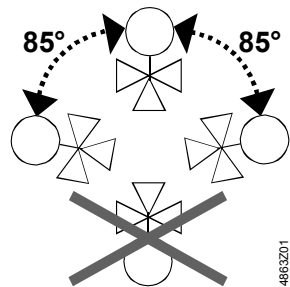

In addition, the direction of flow as described under «Engineering notes» must be observed.

Mounting

Assembly is made with the coupling nut; no adjustments are required.
The actuator must be fitted in position 1 (also refer to « Manual operation »):

- Position the actuator and tighten the coupling nut manually
- Do not use any tools such as wrenches

Caution 

Suitable conduit shall connect to the actuator when undergone the wiring work of the product.

Manual operation

Open valve manually

Turn switch with approximately 90 % valve stroke latch

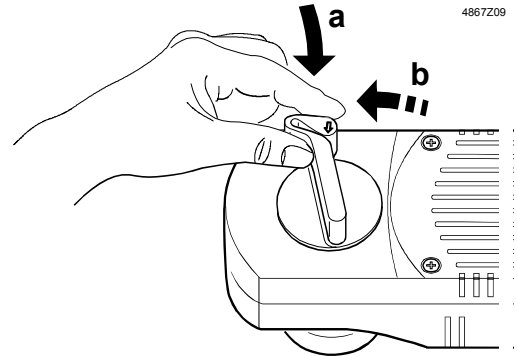
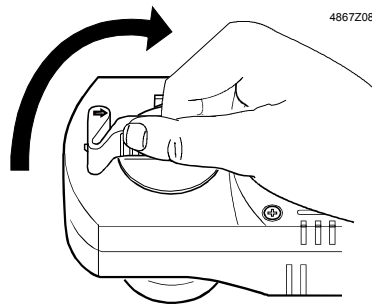

Release switch manually

Switch up to the impact turn and release

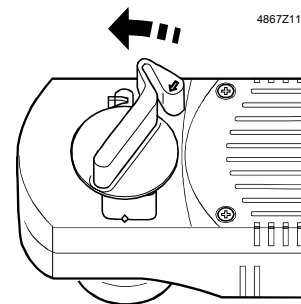
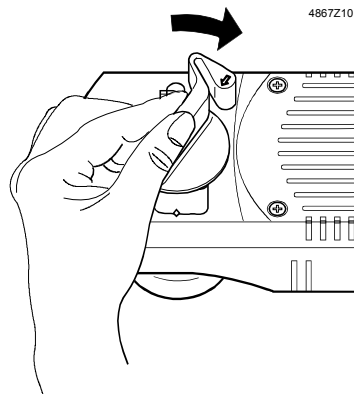

Commissioning notes

Manual adjustment

Through operation of the manual adjuster or removed the actuator, the through-port AB → A of the valve can be opened. With the 3-port valves, the bypass port will be closed. The valves will be opened by their own spring (normally open).

Warning 

Before performing any service work on the valve and/or actuator:

- **Switch OFF the pump and power supply.**
- **Close the main shut-off valve in the pipe work.**
- **Release pressure in the pipes and allow them to cool down completely.**
- **If necessary, disconnect electrical connections from the terminals.**

The valve may be commissioned only with the manual wheel pre-set or with a correctly mounted actuator.

Maintenance

The valve and actuator do not require maintenance
 Faulty actuators can be replaced without removing the valve from the pipe work.
 The actuator cannot be repaired.

Replacement actuator

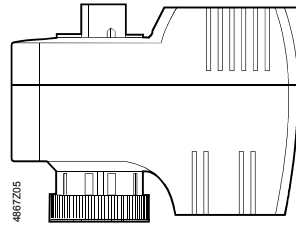

Replacement actuators (AC 230 V versions) can be ordered by quoting type code : SFA21

Disposal



The valve must be dismantled and separated into its various constituent materials before disposal.

The actuator may not be disposed of together with domestic waste.

Legislation may demand special handling of certain components, or it may be sensible from an ecological point of view.

Current local legislation must be observed.

Warranty

The technical data supplied for these valves is valid only for valves used in conjunction with the actuators SFA....

Use with third-party actuators invalidates any warranty offered by Siemens Building Technologies / HVAC Products.

Technical data

Valves

Operating data	PN class	PN16 to EN1333
	Permissible operating pressure	2000 kPa (20 bar)
	Valve characteristic	The trim is designed for ON/OFF control only
	Leakage	According to DIN EN 1349
	2-port valve:	
	Path A → AB	0...0.05 % of k_{vs}
	3-port valve	
	Path AB ↔ A	0...0.05 % of k_{vs}
	Bypass AB ↔ B	Max. 2...5 % of k_{vs}
	Admissible media	Chilled water, low-temperature hot water and water with frost protection additives. Recommendation: water should be treated as specified in VDI 2035
Temperature of medium	1...110 °C, or max. 120 °C for brief period	
Nominal stroke	2.5 mm	
Materials	Valve body	Hot-pressed brass
	Stem	Stainless steel
	Plug, seat, gland	Brass or bronze Rg5
	Stem seal	EPDM O-rings
Dimensions / Weight	Dimensions and weight	See «Dimensions»
	Threaded connections (Valve)	Rp to ISO7/1

Actuators		
Power supply	Rated voltage	AC 230 V
	Voltage tolerance	-15 / +10 %
	Rated frequency	50 Hz
	Max. power consumption	9.8 VA
	Fuse protection for incoming cable	Max. 3 A (external)
Control	Control signal	2-position via temperature controller Phase cut and pulse-width-modulated signals are not suitable.
	Opening/closing operations	Recommended number: approx. 10 000 / year (equivalent to approx. 50 per day)
Functional data	Position with de-energized actuator	
	2-port valve (MVI421...)	A → AB closed
	3-port valve (MXI421...)	AB ↔ A closed
	Running time	30...50 s (opened by motor, closed by spring force)
	Nominal stroke	2.5 mm
Electrical connection	Nominal force	105 N
	Manual adjustment	90 %
Industry standards	Lead wire	3-core 0.15 m
Dimensions / Weight	Meets the requirements for CE marking:	
	EMC Directive	89/336/EEC
	Low Voltage Directive	73/23/EEC
	Protection class	I to EN 60730, Section 2.7
Materials	Housing protection standard	IP30 to EN60529
	Dimensions and weight	See «Dimensions»
	Weight auxiliary switch	0.150 kg
	without auxiliary switch	0.585 kg
Housing colors	with auxiliary switch	0.692 kg
	Base-plate	Die-cast aluminum
Auxiliary switch ASC2.1/18	Housing	Polycarbonate
	Base and cover	Light gray, RAL7035
General ambient conditions	Switch type	Changeover contact
	Switching point	At approx. 50 % stroke
	Switching capacity	AC 250 V/ 3 A resistive, 2 A inductive
	Connecting cable	3-core, 1.8 m / AWG18 (0.96 mm ²)

General ambient conditions	Operation	Transport	Storage
	IEC 721-3-3	IEC 721-3-2	IEC 721-3-2
Environmental conditions	Class 3K3	Class 2K3	Class 2K3
Temperature	+1...+50 °C	-25...+70 °C	-5...+50 °C
Humidity	5...85 %r.h.	< 95 %r.h.	5...95 %r.h.

Connecting cable and terminals

Actuator

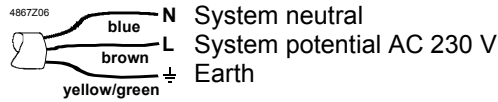

Auxiliary switch ASC2.1/18

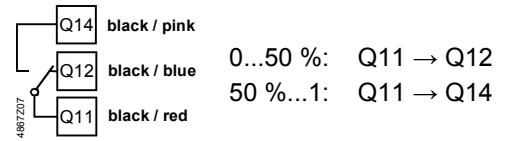

Connection diagram

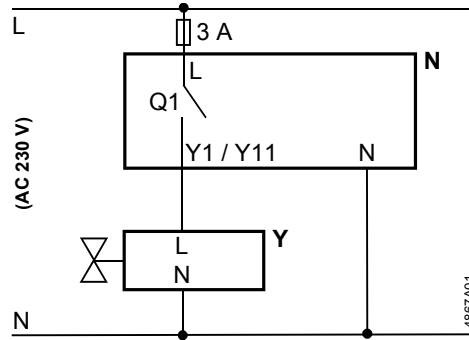

- N Controller (thermostat)
- Y Actuator with zone valve
- L System potential AC 230 V
- N System neutral
- Y1 Control signal OPEN
- Q1 Controller contact

Dimensions

All dimensions in mm

2-port valves
MVI421...

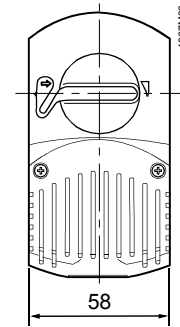
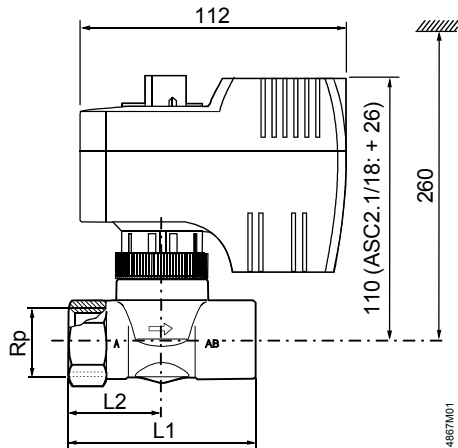

Type	DN	Rp [inches]	L1 [mm]	L2 [mm]	W [kg]
MVI421.15	15	Rp $\frac{1}{2}$	60	30	0.865
MVI421.20	20	Rp $\frac{3}{4}$	65	32.5	0.895
MVI421.25	25	Rp1	84	42	1.105

3-port valves
MXI421...

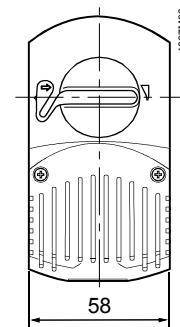
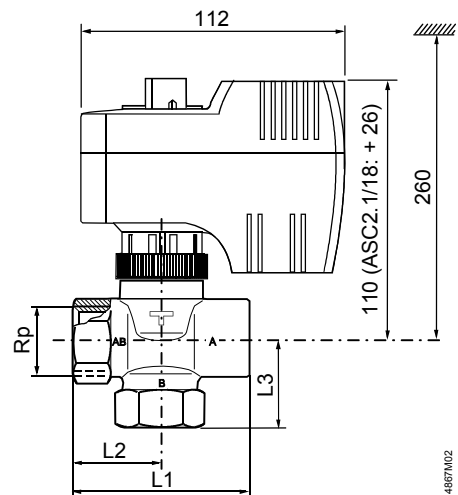

Type	DN	Rp [inches]	L1 [mm]	L2 [mm]	L3 [mm]	W [kg]
MXI421.15	15	Rp $\frac{1}{2}$	60	30	30	0.934
MXI421.20	20	Rp $\frac{3}{4}$	65	32.5	32.5	0.965
MXI421.25	25	Rp1	84	42	40	1.215