

MXG461...

MXF461...

Modulating control valves MXG461... PN 16 with magnetic actuators MXF461...

for chilled and low-temperature hot water systems

-
- **Fast positioning time (< 2 s), high-resolution stroke (1 : 1000)**
 - **Equal-percentage or linear valve characteristic (user-selected)**
 - **High rangeability**
 - **Operating voltage AC 24 V**
 - **Switch-selected control signal DC 0/2...10 V or DC 4...20 mA**
 - **DC 0...20 V phase cut control signal with SEZ91.6 external interface**
 - **Indication of operating state**
 - **Positioning control, position feedback and manual control**
 - **Wear-free inductive stroke measurement**
 - **Fail-safe feature: A → AB closed when de-energised**
 - **Low friction, robust, no maintenance required**

Use

The control valves are mixing or throughport valves. They are supplied with the magnetic actuator ready fitted, equipped with an electronics module for position control and position feedback.

The short positioning time, high resolution and high rangeability make these valves ideal for modulating control of chilled and low-temperature hot water systems in closed circuits of heating, ventilating and air conditioning systems.

Valves for media containing mineral oils: refer to data sheet N4456.

Special silicon-free version available, type suffix ...M.

Type summary

Type reference	DN	k_{vs}	Δp_{max}	Δp_s	S_{NA}	P_{med}	I_N	Wire cross-section [mm ²] 4-wire connection		
		[m ³ /h]	[kPa]	[kPa]	[VA]	[W]	[A]	1,5	2,5	4,0
MX...461.15-0.6	15	0.6	300	300	29	5	3.15	70	110	170
MX...461.15-1.5		1.5								
MX...461.15-3.0		3.0								
MX...461.20-5.0	20	5.0								
MX...461.25-8.0	25	8.0								
MX...461.32-12	32	12								
MX...461.40-20	40	20			44	6	4	40	70	110
MX...461.50-30	50	30								
MXF461.65-50	65	50			46					

... = F for flanged valves
G for screwed valves

Δp_{max} = max. permissible differential pressure across the valve's control path, valid for the entire actuating range of the motorised valve

Δp_s = max. permissible differential pressure (close off pressure) at which the motorised valve will close securely against the pressure (used as throughport valve)

S_{NA} = nominal apparent power for selecting the transformer

P_{med} = typical power consumption

I_N = required slow fuse

k_{vs} = nominal flow rate of cold water (5 to 30 °C) through the fully openend valve (H_{100}) at a differential pressure of 100 kPa (1 bar)

L = max. cable length; with 4-wire connections, the max. permissible length of the separate 1.5 mm² copper positioning signal cable is 200 m

Flanged valves DN80, DN100: M3P80FY, M3P100FY, refer to data sheet N4454

Valves for media containing mineral oils with type suffix ...P (MXG461...P, MXF461...P), refer to data sheet N4456

Silicon-free valves with type suffix ...M (MXG461...M, MXF461...M)

Accessories

Type reference	Description
ALG...3 (... = DN)	Set of 3 screwed fittings for 3-port valves, consisting of - 3 union nuts - 3 discs and - 3 flat seals
Z155/... (... = DN)	Blank flange set with blank flange, seal, screws, spring washers and nuts
SEZ91.6	External interface for DC 0...20 V phase cut control signal, refer to data sheet N5143

Order

When ordering, please give quantity, product name and type reference.

Example:
3 screwed valves MXG461.25-8.0
3 sets of 3 screwed fittings ALG253
4 flanged valves MXF461.20-5.0
2 blank flange sets Z155/20F

Delivery

Valve body and magnetic actuator form one assembly and cannot be separated.
The screwed fitting sets and blank flanges are packed and supplied separately.

Replacement electronics module ASE1, ASE2

Should the valve electronics prove faulty, the electronics module must be replaced by the ASE1 (DN15...32) or ASE2 (DN40...65) replacement electronics module.
Mounting Instructions no. 35678 are included.

For a detailed description of operation, refer to data sheet CA1N4028E.

Control operation

The electronics module converts the positioning signal to a phase-cut power signal which generates a magnetic field in the coil. This causes the armature to change its position in accordance with the interacting forces (magnetic field, counterspring, hydraulics). The armature responds rapidly to any change in signal, transferring the corresponding movement directly to the valve plug, enabling fast changes in load to be corrected quickly and accurately.

The valve's position is measured continuously (inductive). The internal positioning controller balances any disturbance in the system rapidly and delivers the position feedback signal. The valve stroke is proportional to the positioning signal.

Spring return facility

If the positioning signal is interrupted, or in the event of a power failure, the valve's return spring will automatically close control path A → AB.

Control

The magnetic actuator can be driven by a Siemens controller or a controller of other manufacture that deliver a DC 0/2...10 V or DC 4... 20 mA output signal. To achieve optimum control performance, it is recommended to use a 4-wire connection.

Operator controls and indicators in the electronics housing

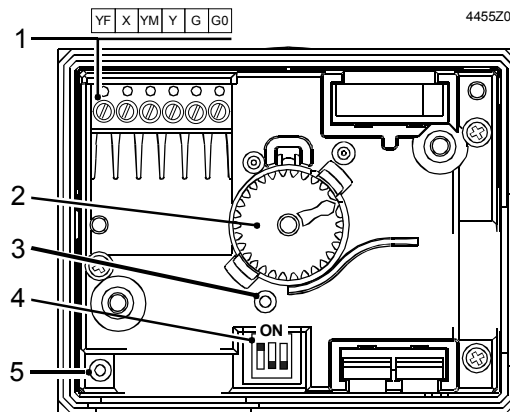

- 1 Connection terminals
- 2 Hand wheel
- 3 Opening for autocalibration
- 4 DIL switch for mode control

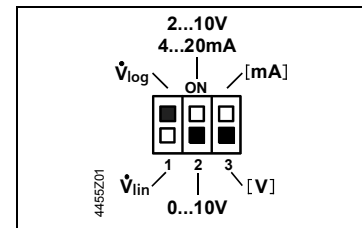



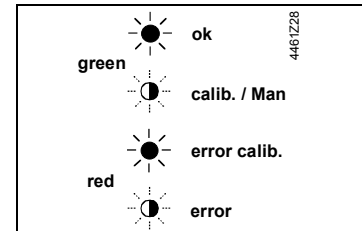

- 5 LED for indication of operating stat



Indication of operating state

The two-colour LED display indicating operating status can be viewed by opening the cover of the electronics module.

LED	Indication	Function	Remarks, troubleshooting
Green	Lit 	Control mode	Automatic operation; everything o.k.
	Flashing 	Calibration In manual control	Wait until calibration is finished (green or red LED will be lit) Hand wheel in MANUAL or OFF position
Red	Lit 	Calibration error	Recalibrate (operate button in opening 1x)
	Flashing 	Internal error Mains fault	Replace electronics module Check mains network (outside the frequency or voltage range)
Both	Dark 	No power supply Electronics faulty	Check mains network, check wiring Replace electronics module

As a general rule, the LED can assume only the states shown above (continuously red or green, flashing red or green, or off).

Manual control

MANUAL

The valve control path (ports A → AB) can be opened manually to between 80 and 100% of the full stroke (depending on DN) by pressing the hand wheel inwards and turning it clockwise (MANUAL setting). This disables the control signal from the controller, the green LED is flashing.

OFF

To disable automatic control of the valve, press the hand wheel inwards and turn it anti-clockwise (to the OFF position). The valve will close, the green LED is flashing.

AUTO

For automatic control, the hand wheel must be set to the AUTO position (the hand wheel will spring out), the green LED is lit.

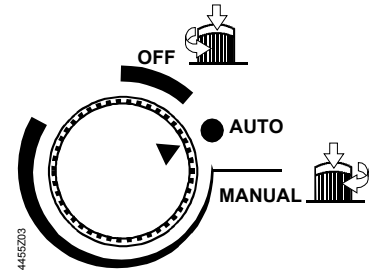

Calibration

The MX...461... magnetic valves are factory-calibrated at 0 % and 100 % stroke.

When commissioning the valves, however, (especially under extreme conditions of use) there may still be some leakage via control path A → AB with a 0 % stroke control signal (DC 0 V, DC 2 V or DC 4 mA). In this case, the valve can be recalibrated simply and quickly:

1. Hand wheel in AUTO-position
2. Use a pointed implement (\varnothing 2 mm) to operate the button in the opening [3] once
3. While recalibration is in progress, the LED [5] is flashing green for approximately 10 seconds.

The valve will be briefly closed and fully opened.

If the electronics module is replaced, the valve's electronics must be recalibrated. For that, the hand wheel must be set to AUTO.

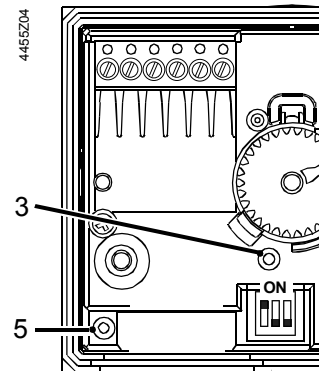

Configuration DIL switches

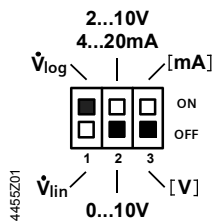

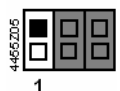
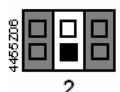
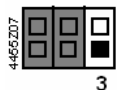
Switch	Function	ON / OFF	Description
 1	Valve characteristic	ON	\dot{V}_{\log} (equal percentage) ¹⁾
		OFF	\dot{V}_{lin} (linear)
 2	Positioning signal Y	ON	DC 2...10 V, DC 4...20 mA
		OFF	DC 0...10 V ¹⁾
 3	[V] or [mA] assignment	ON	[mA]
		OFF	[V] ¹⁾

1) Factory setting

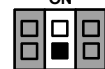
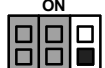
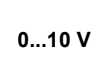
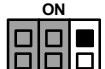
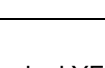
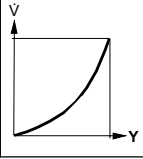
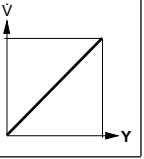
Assignment positioning signal Y: Voltage or current	Selection of valve characteristic (Positioning signal against volumetric flow): Equal-percentage or linear	
 		
	0...10 V	2...10 V
		4...20 mA
		

Forced control input

If terminal YF for the forced control input

- is not connected, the valve will follow the Y-signal
- is connected to G, the valve will fully open control path A → AB
- is connected to G0, the valve will close control path A → AB

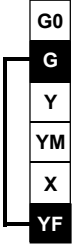
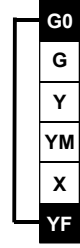
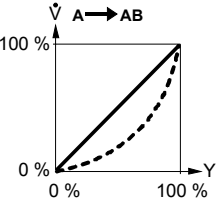
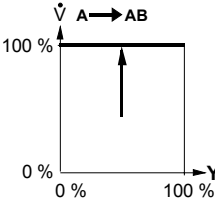
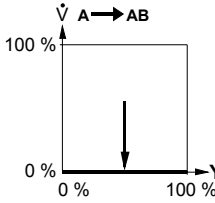
YF-Function			
	no function	fully open	closed
Connections			
Transfer			

Signal priority

1. Hand wheel position MANUAL (open) or OFF (close)
2. Forced control signal YF
3. Signal input Y

Flow chart

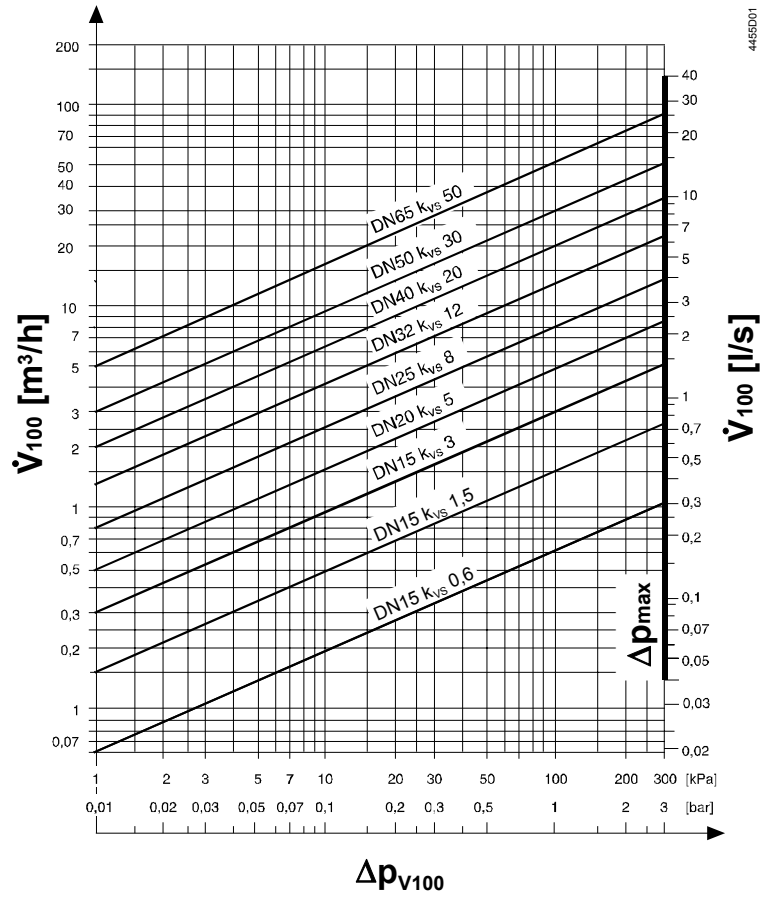

- Δp_{V100} = differential pressure across the fully open valve and the valve's control path A → AB by a volume flow \dot{V}_{100}
- \dot{V}_{100} = volume flow through the fully open valve (H_{100})
- Δp_{max} = max. permissible differential pressure across the valve's control path for the entire actuating range of the motorised valve
- 100 kPa = 1 bar ≈ 10 mWC
- 1 m³/h = 0.278 l/s water at 20 °C

Valve characteristic

Equal percentage

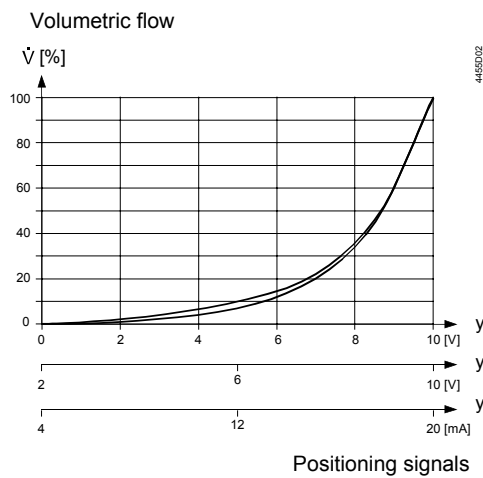

Linear

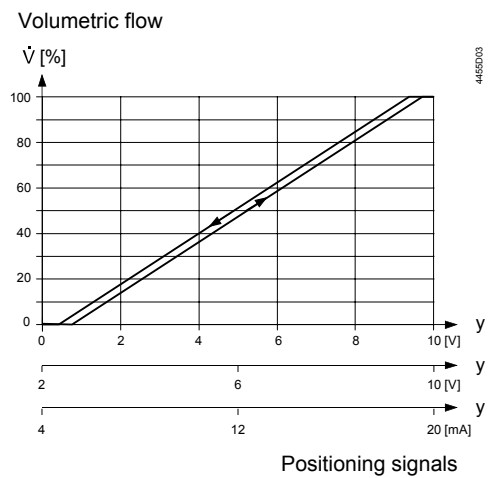

Mounting notes

Mounting and operating instructions are printed on the actuator and on the electronics module.

Caution 

The valve may only be used as a mixing or throughport valve, not as a diverting valve. Observe the direction of flow!

A strainer should be fitted upstream of the valve. This increases reliability.

Orientation

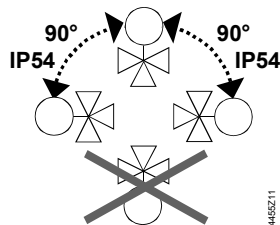

Degree of protection valid only when M20 cable gland supplied by the installer.

Access for installation

It is essential to maintain the specified minimum clearance above and to the side of the actuator and/or electronics module! (refer to «Dimensions»)

DN15...DN32 = 100 mm

DN40...DN65 = 150 mm

Use as straight-through valves

Only three-way MX...461... valves are supplied. They may be used as straight-through valves by closing off port «B».

MXG461... screwed valves in straight-through applications

Port «B» can be sealed with the accessories supplied (cover, gasket) and the union nut of the ALG...3 coupling.

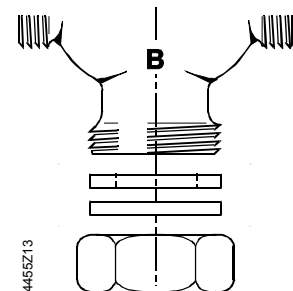

MXF461... flanged valves in straight-through applications

Port «B» can be sealed with part Z155/... which must be ordered as a separate item. The part comes complete with blank flange, seal, screws, spring washers and nuts.
 DN15...DN32 blank flange (Z155/15F...Z155/32F)
 DN40...DN65 blank flange (Z155/40...Z155/65)

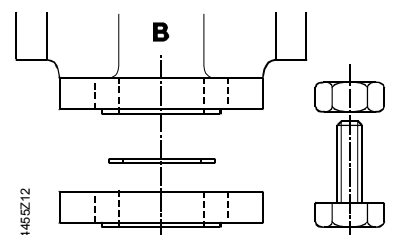

Installation notes

- The MXG...461... valves are flat-faced allowing sealing with the gaskets provided with the ALG...3 set of 3 screwed fittings.
- Do not use hemp for sealing the valve body threads.
- The actuator may not be lagged.

For notes on electrical installation, see «Connection diagram»

Maintenance notes

The valves and actuators are maintenance-free.

The low friction and robust design make regular servicing unnecessary and ensure a long service life.

The valve stem is sealed from external influences by a maintenance-free gland.

If the red LED is lit, the electronics must be recalibrated or replaced.

Repair

Should the valve electronics prove faulty, the electronics module must be replaced by the ASE1 (DN15...32) or ASE2 (DN40...65) replacement electronics module. Mounting Instructions no. 35678 are included.

Caution  **Always disconnect power before fitting or removing the electronics module.**

After replacing the electronics module, calibration must be triggered in order to optimally match the electronics to the valve (refer to «Calibration»).

Caution  **Under operating conditions within the limits defined by the application data, the actuator will become hot, but this does not represent a burn risk. Always maintain the minimum clearance specified, refer to «Dimensions».**

Disposal



The actuator must not be disposed of together with domestic waste. This applies in particular to the PCB.

Legislation may demand special handling of certain components, or it may be sensible from an ecological point of view

Current local legislation must be observed.

Warranty

Application-specific technical data must be observed.

If specified limits are not observed, Siemens Switzerland Ltd / HVAC Products will not assume any responsibility.

Technical data

Functional actuator data

Power supply

Extra low-voltage only (SELV, PELV)

Operating voltage AC 24 V +20 / -15 %

Frequency 45...65 Hz

Typical power consumption P_{med} refer to table «Type summary»

Standby < 1 W (valve closed)

Rated apparent power S_{NA} refer to table «Type summary»

Required fuse I_N slow, refer to table «Type summary»

Input

Positioning signal Y DC 0/2...10 V or DC 4...20 mA

Impedance DC 0/2...10 V 100 k Ω // 5nF

DC 4...20 mA 100 Ω // 5nF

Forced control

Impedance 22 k Ω

Close valve (YF connected to G0) < AC 1 V

Open valve (YF connected to G) > AC 6 V

No function (YF not wired) positioning signal Y active

Output

Position feedback signal DC 0...10 V; load resistance > 500 Ω

Stroke measurement Inductive

Nonlinearity \pm 3 % of end value

Functional valve data

	PN class	PN 16 to EN 1333
	Permissible operating pressure	1 MPa (10 bar)
	Differential pressure $\Delta p_{\max} / \Delta p_s$	refer to table «Type summary»
	Leakage rate at $\Delta p = 0.1 \text{ MPa (1 bar)}$	A → AB max. 0.02 % k_{VS} (to DIN EN 1349) B → AB depending on operating conditions ($< 0.2 \text{ % } k_{VS}$)
	Permissible media	chilled and low-temperature hot water, water with anti-freeze; recommendation: water treatment to VDI 2035
	Medium temperature	1...130 °C
	Valve characteristic ¹⁾	equal percentage, $n_{gl} = 5.3$ nach VDI / VDE 2173 or linear, optimized near the closing point
	Stroke resolution $\Delta H / H_{100}$	1 : 1000 (H = stroke)
	Hysteresis	typically 3 %
	Mode of operation	modulating
	Position when deenergized	A → AB closed
	Mounting position	upright to horizontal (note that orientation affects protection standard)
	Positioning time	< 2 s
Materials	Valve body	Cast iron EN-GJL-250
	Plug	CrNi steel (X12CrNiS18 8)
	Seat	brass (CuZn39Pb3)
	Valve stem seal	EPDM (O-ring)
	Bellows	Tombac (CuSn6), bronze (CuSn9), CrNi steel
Electrical connection	Cable entry	2 x $\varnothing 20.5 \text{ mm}$ (for M20)
	Connection terminals	screw terminals for 4 mm ² wire
	Minimal wire cross section	1.5 mm ²
	Maximum cable length	refer to «Type summary»
Dimensions / weight	Dimensions	refer to « Dimensions»
	Weight	refer to « Dimensions»
Norms and standards	Degree of protection	to IEC 60529
	Mounting pos. upright to horizontal	IP54 (with M20 cable gland)
	Conforming to	CE requirements UL 873 certified to Canadian standard C22.2 No. 24 C-Tick N 474
	Permissible operating pressure	PED 97/23/EC
	Pressure accessories	as per article 1, section 2.1.4
	Fluid group 2:	• DN15...DN50 • without CE-marking as per article 3, section 3 (sound engineering practice) • DN 65 • category I, with CE-marking
	Immunity	Industrial IEC 61000-6-2 ²⁾
	Immunity (HF)	IEC 1000-4-3; IEC 1000-4-6 (10 V/m)
	Emission	Residential IEC 61000-6-3
	Emission (HF)	EN 55022, CISPR 22, class B
	Vibration ³⁾	IEC 68-2-6 (1 g acceleration, 1...100 Hz, 10 min)

¹⁾ Can be selected via DIL switch

²⁾ Transformer 160 VA (e.g. Siemens 4AM 3842-4TN00-0EAO)

³⁾ In case of strong vibrations, use high-flex stranded wires for safety reasons.

General environmental conditions

	Operation EN 60721-3-3	Transport EN 60721-3-2	Storage EN 60721-3-1
Climatic conditions	Class 3K5	Class 2K3	Class 1K3
Temperature	-5...+45 °C	-25...+70 °C	-5...+45 °C
Humidity	5...95 % r.h.	5...95 % r.h.	5...95 % r.h.
Mechanical conditions	EN 60721-3-6 Class 6M2		

Connection diagram

Caution  **If controller and valve receive their power from separate sources, only one transformer may be earthed on the secondary side.**

With controllers
DC 0...10 V
DC 2...10 V
DC 4...20 mA

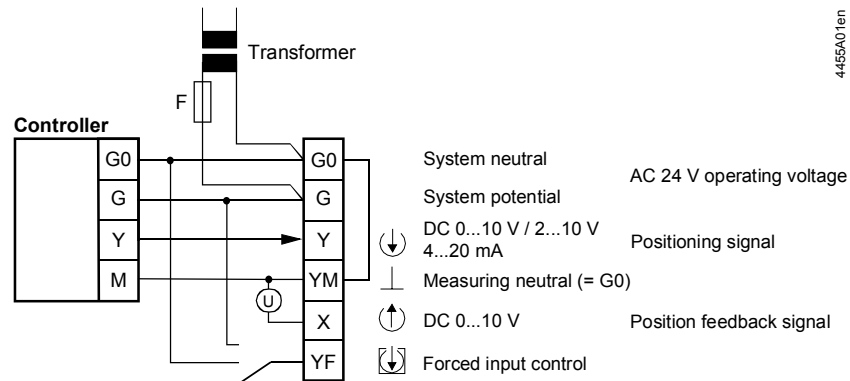

Application examples

Hydraulic circuits

The examples shown below are basic diagrams with no installation-specific details.

Caution  **The valve may only be used as a mixing or throughport valve, not as a diverting valve. Observe the direction of flow!**

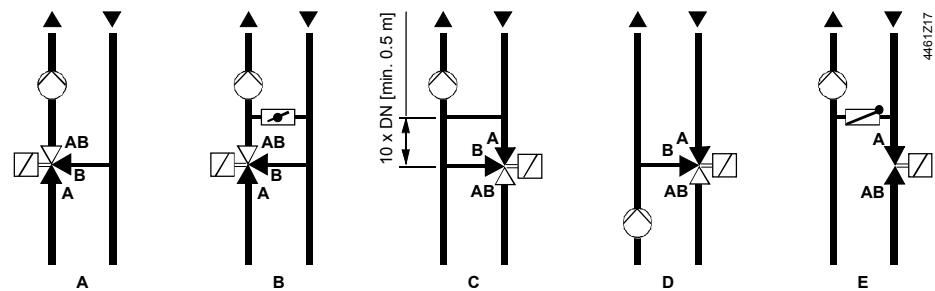

- A Mixing circuit
- B Mixing circuit with bypass (underfloor heating system)
- C Injection circuit
- D Diverting circuit
- E Injection circuit with throughport valve

Dimensions

Dimensions in mm

MXG461... screwed valves

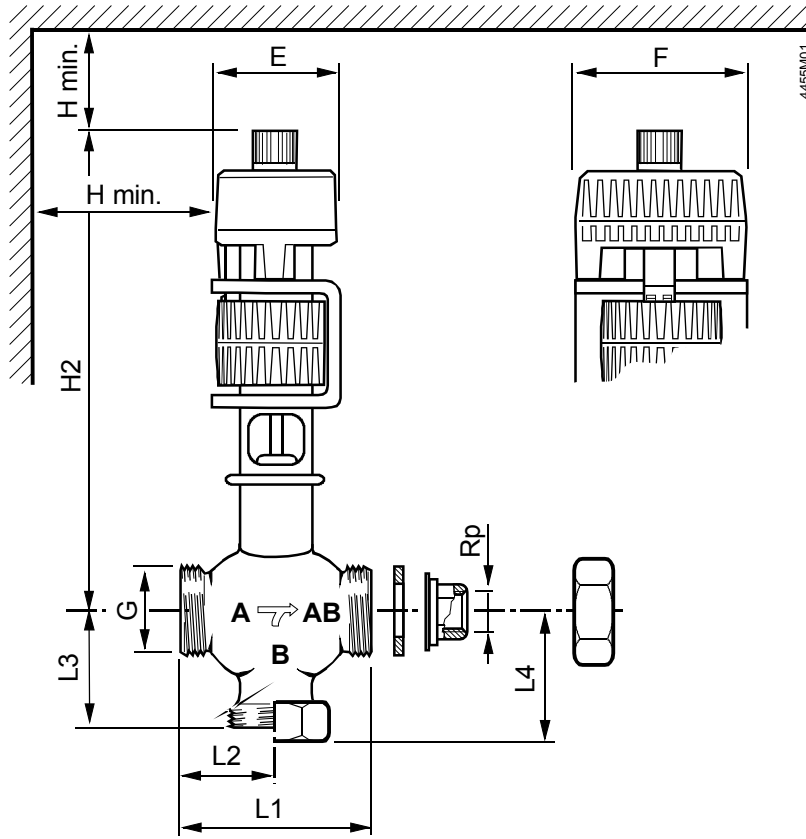

Type reference	DN	Rp [inch]	G [inch]	L1	L2	L3	L4	H2	H min.	E	F	Weight [kg]
MXG461.15-0.6	15	Rp½	G1B	80	40	42.5	51	240	100	80	100	3.8
MXG461.15-1.5												
MXG461.15-3.0												
MXG461.20-5.0	20	Rp¾	G1½B	95	47.5	52.5	61	260				
MXG461.25-8.0	25	Rp1	G1½B	110	55	56.5	65	270				
MXG461.32-12	32	Rp1¼	G2B	125	62.5	67.5	76	285				
MXG461.40-20	40	Rp1½	G2½B	140	70	80.5	94	320	150			9.3
MXG461.50-30	50	Rp2	G2½B	170	85	93.5	109	340				11.9

Remarks:

- L4: When used as a throughport valve
- Internally threaded Rp... to ISO 7-1
- Externally threaded G...B to ISO 228-1
- Fittings to ISO 49 / DIN 2950

MXF461...
flanged valves

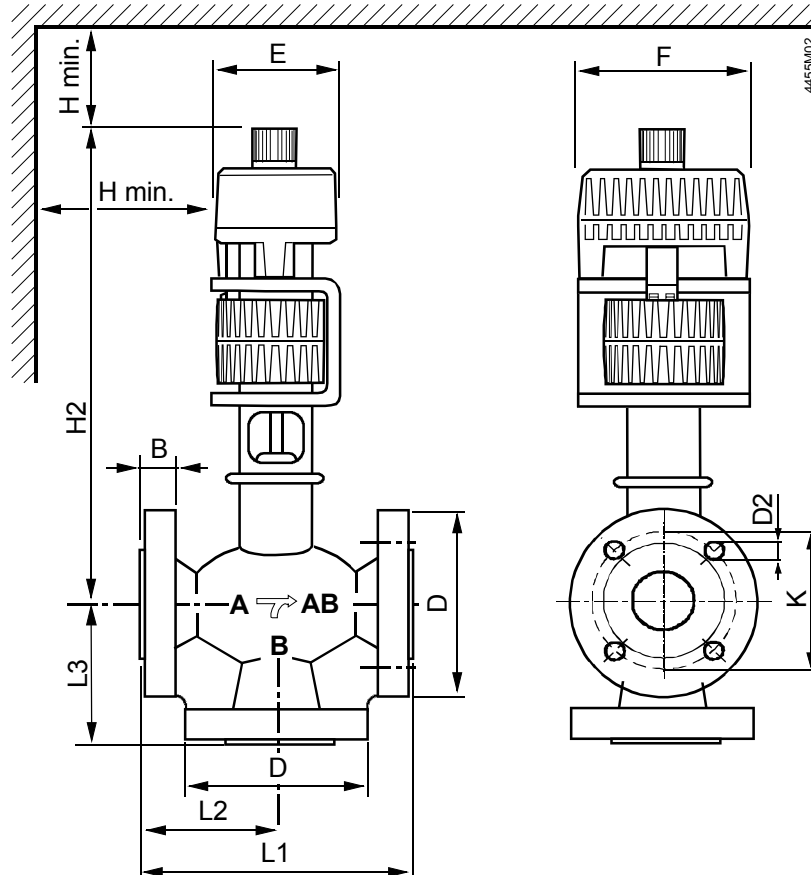

Type reference	DN	B	D ∅	D2 ∅	K	L1	L2	L3	H2	H min.	E	F	Weight [kg]
MXF461.15-0.6	15	14	95	4x14	65	130	65	65	250	100	80	100	5.8
MXF461.15-1.5													
MXF461.15-3.0													
MXF461.20-5.0	20	16	105	4x14	75	150	75	75	260	100	80	100	7.0
MXF461.25-8.0			25		115	85	160	80	80				272
MXF461.32-12	32	18	140	4x18	100	180	90	90	285	150	80	100	11.0
MXF461.40-20	40		150		110	200	100	100	322				15.4
MXF461.50-30	50	22	165	4x18	125	230	115	105	340	150	80	100	19.8
MXF461.65-50	65		185		145	290	145	125	392				28.6

Remarks:

- Counter-flanges must be supplied by the installer!
- Flange dimensions to ISO 7005-2 / DIN 2533, PN 16