



Synco™ 700

Central Control Unit

RMB795

for use with RXB... room controllers



- 10 autonomous room groups
- Freely programmable, for optimum adaption to the relevant type of plant
- Menu-driven operation with separate operator unit (plug-in type or detached)
- Konnex bus connection for operation and process information

Use

The RMB795 central control unit affords central operation of room groups equipped with RXB room controllers with selectable time schedules, calendar and special day programs, preselected setpoints, trend functions, monitoring of highest/lowest temperatures and devices, and passing on of request signals to the primary side. Menu-driven operation of the RMB795 is made possible with a plug-in type or detached operator unit.

Functions

Time switch

- Yearly time switch with automatic summer-/wintertime changeover

Room groups

- Up to 10 individual room groups can be configured on 1 central control unit
- 1 room group serves a total of 1 to 63 RXB room controllers, with the same
 - room operating modes
 - room setpoints
 - setpoint adjustments (summer/winter compensation)
 - emergency operating modes and application operating modes
- Each room group has its own 7-day program (6 switching points per day); time switch entries can be copied
- Each room group is assigned a calendar with 16 programmable time periods and can act on several time switches or room groups

Reference rooms	<ul style="list-style-type: none"> • 1 to 3 reference rooms can be defined as specially selected individual rooms for calculating the "Night cooling" function. The temperatures of the reference rooms per room group can be viewed
Highest/lowest room temperature	<ul style="list-style-type: none"> • For each room group, the highest and the lowest current room temperatures are displayed. This provides a good overview of the temperature spread in a room group
Operation of RXB room controller	<ul style="list-style-type: none"> • Using the "RXB operation" function, a number of RXB datapoints can be read and written. These are selected values such as room number, actual values, setpoints, operating mode and current heat and refrigeration requests. The datapoints displayed are dependent on the RXB room controller and its application
Trend	<ul style="list-style-type: none"> • There are up to 4 independent trend channels for recording measured values. In addition to the local inputs of the RMB795, room temperatures and the outside temperature delivered via the bus can be recorded
Universal inputs	<p>6 universal inputs for:</p> <ul style="list-style-type: none"> • Passive or active analog input signals of the following measured values (°C, %, g/kg, kJ/kg, W/m², bar, mbar, m/s, Pa, and ppm) • Digital input signals (potential-free contacts)
Switching and supervisory functions	<ul style="list-style-type: none"> • Fault indication with red LED, acknowledgement with button. In addition, 2 relay outputs can be configured as fault relays, 10 universal inputs as fault status inputs • Fire alarm off: Using an input signal, RXB room controllers assigned to a room group can be switched off in case of emergency • Smoke extraction: Using 1 or 2 input signals, a room group can be switched to "Smoke extraction" mode • Device supervision is used to check the connected RXB room controllers per room group and to detect RXB failures • If the RXB room controllers are used in connection with a 2-pipe system for heating / cooling, the heating/cooling changeover signal from the RMB795 central control unit can be delivered to the RXB room controllers via bus using a digital input
Functions with universal modules	<ul style="list-style-type: none"> • Extra inputs and outputs for extending the central control unit's functionality (e.g. fault status messages, etc.) • Can be extended with 1 RMZ785 and 2 RMZ787 universal modules
Bus functions	<ul style="list-style-type: none"> • QAW740 room operator unit can be assigned per room group • Indication of fault status messages delivered by other devices on the bus • Delivery of a common fault status message from all devices on the bus to a fault relay • Time synchronization • Passing on and adoption of outside temperature signal • Sending the yearly clock data (time of day, weekday, date, summer-/wintertime changeover) to another device or reception of yearly clock data from another device • Transmitting room group information (e.g. 7-day or yearly program for holidays/ special days) to RXB room controllers • Reception and transmission of request signals (hot or chilled water)
Service and operating functions	<ul style="list-style-type: none"> • Outside temperature simulation • Wiring test • Data protection • Display of actual values and active limitations

Type summary

Unit	Type reference	Universal inputs	Positioning outputs	Switching outputs	Default languages
	RMB795-1	6	2	4	de, fr, it, es
	RMB795-2	6	2	4	de, fr, nl, en
	RMB795-3	6	2	4	da, fi, no, sv
	RMB795-4	6	2	4	cs, sk, pl, hu
	RMB795-5	6	2	4	ro, sl, sr, hr

Accessories	Name	Type reference	Data Sheet
Operator / service units	Operator unit, plug-in type	RMZ790	N3111
	Operator unit, detached	RMZ791	N3112
	Service tool	OCI700.1	N5655
Extension modules	Universal module with 8 universal inputs	RMZ785	N3146
	Universal module with 4 universal inputs and 4 relay outputs	RMZ787	N3146
	Module connector for detached extension modules	RMZ780	N3138

Ordering and delivery

When ordering, please give name and type reference, for example:

Central control unit **RMB795-2**.

The devices listed under "Accessories" must be ordered as separate items.

Equipment combinations

For equipment combinations, refer to "Product Range Overview Synco™700".

Product documentation

Name	Ordering number
Product Range Overview Synco™700	CE1S3110en
Basic Documentation, detailed description of all functions	CE1P3121en
Installation Instructions (mounting and commissioning) G3140	74 319 0398 0
Operating Instructions (de, fr, nl, en) B3121x2	74 319 0462 0
Data Sheet "Konnex bus KNX"	CE1N3127en
Basic Documentation "Communication via Konnex bus for devices of the Synco™700 series and RXB room controller"	CE1P3127en
Declaration of Conformity (CE)	CE1T3110xx
Environmental Declaration	CE1E3110en01

Technical design

With the help of the RMZ790 or RMZ791 operator unit, the RMB795 affords:

- Free configuration of applications
- Optimization of RXB room controller settings

For operating actions of the functions, refer to the Basic Documentation CE1P3121en.

Mechanical design

The unit consists of insert and terminal base. The terminal base has 2 levels of terminals and a connection facility (electrical and mechanical) for using 1 extension module. The insert with its printed circuit boards is attached to the terminal base. It can be mounted on a top hat rail conforming to EN 60 715-TH35-7.5, or on a wall. The central control unit is operated either with the plug-in type or detached operator unit (refer to "Accessories").

Operating, display and connecting elements

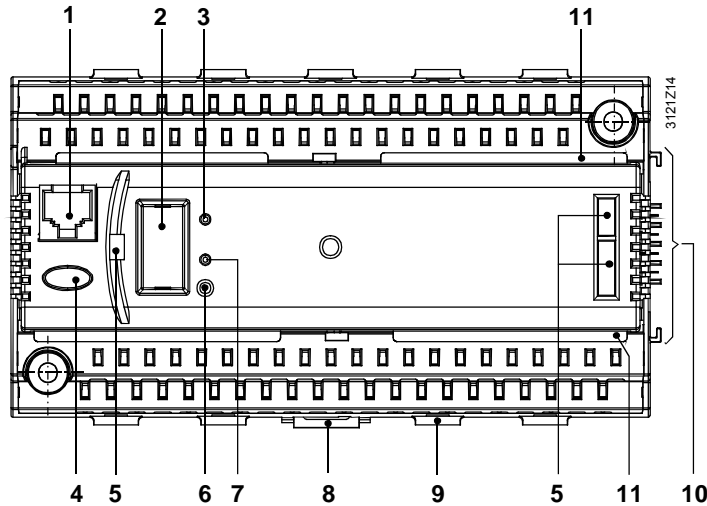

Legend

- | | |
|----|--|
| 1 | Connection facility for the service tool (RJ45 connector) |
| 2 | Removable cover with connection facility for the operator unit |
| 3 | LED "RUN" for indicating the unit's operating state:
<i>LED lit:</i> Power on, no fault in application or peripheral devices
<i>LED off:</i> No power or fault in application/peripheral devices |
| 4 | Button "⏏" with LED (red) for indicating a fault status message and its acknowledgement:
<i>LED flashes:</i> Fault status message, ready for acknowledgement
<i>LED lit:</i> Fault status message still pending but not yet reset
<i>LED dark:</i> No fault status message present
<i>Press button:</i> Acknowledgement of fault, or reset |
| 5 | Openings for plug-in type operator unit RMZ790 |
| 6 | Programming button "Prog": Learning button for switching between normal and addressing mode for adopting the physical device address (tool required) |
| 7 | Programming LED "Prog" for indicating "Normal mode" (LED dark) or addressing mode (LED lit) for adopting the physical device address |
| 8 | Catch for fitting the unit to a top hat rail |
| 9 | Fixing facility for a cable tie (cable strain relief) |
| 10 | Electrical and mechanical connection elements for extension module |
| 11 | Rest for the terminal cover |

Engineering notes



- The unit operates on AC 24 V. Operating voltage must conform to the requirements of SELV/PELV (safety extra low-voltage)
- The transformers used must be safety isolating transformers featuring double insulation to EN 60 742 or EN 61 558-2-6; they must be suited for 100 % duty
- Fuses, switches, wiring and earthing must be in compliance with local regulations
- Sensor wires should not be run parallel to mains carrying wires that power fans, actuators, pumps, etc.
- The RMB795 can be used with 1 extension module type RMZ786, RMZ787, or RMZ788

Mounting and installation notes

- Unit and extension modules are designed for:
 - Mounting in a standard cabinet as per DIN 43 880
 - Wall mounting on an existing top hat rail (EN 50 022-35x7.5)
 - Wall mounting using 2 fixing screws
 - Flush panel mounting
- Not permitted are wet or damp spaces. The permissible environmental conditions must be observed
- If the RMB795 shall not be operated inside a control panel, use the detached operator unit RMZ791 in place of the plug-in type operator unit RMZ790
- Disconnect the system from the power supply prior to mounting and installing the RMB795
- **The insert must not be removed from the terminal base!**
- If extension modules are used, they must be attached to the right side of the unit in the correct order in accordance with the internal configuration
- The extension modules require no wiring between themselves or to the controller. The electrical connections are made automatically when attaching the modules. If it is not possible to arrange the extension modules side by side, the first of the detached modules must be connected to the last previous module or to the controller using the RMZ780 module connector. In that case, the cumulated cable length must not exceed 10 m
- All connection terminals for protective extra low-voltage (sensors, data bus) are located in the upper half of the unit, those for mains voltage (actuators and pumps) at the bottom
- Each terminal (spring cage terminal) can accommodate only 1 solid wire or 1 stranded wire. For making the connections, the cables must be stripped for 7 to 8 mm. To introduce the cables into the spring cage terminals and to remove them, a screw driver size 0 or 1 is required. Cable strain relief can be provided with the help of the fixing facility for cable ties
- The RMB795 mounted on a top hat rail together with modules can only be removed from the rail after the module directly attached to the unit has been removed
- The unit is supplied complete with Installation Instructions and Operating Instructions

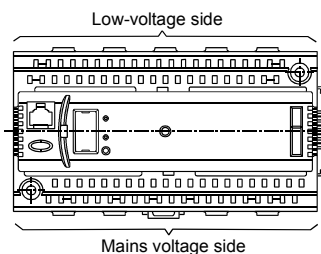

Commissioning notes



- Using the the operator unit RMZ790 or RMZ791, or the service tool, staff trained by **HVAC Products** and having the required access rights can change the configuration and the parameters online or offline at any time
- During the commissioning process, the application is deactivated and the outputs are in a defined off state. This means that no process and alarm signals will then be delivered to the bus
- On completion of the configuration, the controller automatically makes a new start
- When leaving the commissioning pages, the peripheral devices connected to the universal inputs (including the extension modules) are automatically tested and identified. If a peripheral device is missing, a fault status message will be delivered
- The operator unit can be removed and plugged in or connected while the unit is operating
- If adaptations to specific plants are required, they must be recorded and the documentation kept inside the control panel
- For the procedure to be followed when starting up the plant for the first time, refer to the Installation Instructions

Disposal notes

Larger plastic parts carry material identifications conforming to ISO/DIS 11 469 to facilitate environment-compatible disposal.

Technical data

Power supply (G, G0)	Rated voltage	AC 24 V \pm 20 %
	Safety extra low-voltage (SELV) / protective extra low-voltage (PELV) to	HD 384
	Requirements for external safety isolating transformer (100 % duty, max. 320 VA) to	EN 60 742 / EN 61 558-2-6
	Frequency	50/60 Hz
	Power consumption (excl. modules)	12 VA
	Supply line fusing	10 A max.
Functional data	Reserve of clock	12 h
Universal inputs Measured value inputs (X...)	Number	refer to "Type summary"
	Sensors	
	Passive	LG-Ni 1000, T1, Pt 1000 2x LG-Ni 1000 (averaging)
	Active	DC 0...10 V
Status inputs (X...)	Contact sensing	
	Voltage	DC 15 V
	Current	5 mA
	Requirements for status and impulse contacts	
	Signal coupling	potential-free
	Type of contact	maintained or impulse contacts
	Insulating strength against mains potential	AC 3,750 V to EN 60 730
Perm. resistance		
Contacts closed	max. 200 Ω	
Contacts open	min. 50 k Ω	
Outputs Positioning outputs Y...	Number of positioning and switching outputs	refer to "Type summary"
	Output voltage	DC 0...10 V
	Output current	\pm 1 mA
	Max. load	continuous short-circuit
	 Switching outputs AC 230 V (Q1x...Q5x)	External supply line fusing
Non-renewable fuse (slow)		max. 10 A
Automatic line cutout		max. 13 A
Release characteristic		B, C, D to EN 60 898
Cable length		max. 300 m
Relay contacts		
Switching voltage		max. AC 250 V min. AC 19 V
AC current		max. 4 A res., 3 A ind. (cos φ = 0.6)
At 250 V		min. 5 mA
At 19 V		min. 20 mA
Switch-on current		max. 10 A (1 s)
Contact life at AC 250 V		guide values:
At 0.1 A res.		2 x 10 ⁷ cycles
At 0.5 A res.		4 x 10 ⁶ cycles (N. O.) 2 x 10 ⁶ cycles (changeover)
At 4 A res.		3 x 10 ⁵ cycles (N.O.) 1 x 10 ⁵ cycles (changeover)
Red. factor at ind. (cos φ = 0.6)		0.85
Insulating strength		
Between relay contacts and system electronics (reinforced insulation)	AC 3750 V, to EN 60 730-1	
Between neighboring relay contacts (operational insulation)		
Q1 \leftrightarrow Q2;	AC 1250 V, to EN 60 730-1	
Between relay groups (reinforced insulation)		
(Q1, Q2) \leftrightarrow Q3 \leftrightarrow Q5	AC 3750 V, to EN 60 730-1	
Power supply external devices G1	Voltage	AC 24 V
	Current	max. 4 A

Interfaces	Konnex bus	
	Type of interface	Konnex-TP1
	Bus loading number	2.5
	Bus power supply (decentral, can be switched off)	25 mA
	Power failure of short duration to EN 50 090-2-2	100 ms with 1 extension module
	Extension bus	
	Connector specification	4 contacts SELV / PELV
	Number of plugging cycles	max. 10
	Service tool connection facility	RJ45 connector
Perm. cable lengths	For passive measuring and positioning signals	(measuring errors can be corrected on the "Settings / Inputs" menu)
	Type of signal	max. 300 m
	LG-Ni 1000, T1	max. 300 m
	Pt 1000	max. 300 m
	Contact sensing	max. 300 m
	For DC 0...10 V measuring and control signals	refer to Data Sheet of the signal delivering device
	For Konnex bus	max. 700 m
	Type of cable	2-core without shielding, twisted pairs
Electrical connections	Connection terminals	spring cage terminals
	For wires	0.6 mm dia...2.5 mm ²
	For stranded wires without ferrules	0.25...2.5 mm ²
	For stranded wires with ferrules	0.25...1.5 mm ²
	Connection facility for Konnex bus	wires cannot be interchanged
Degrees of protection	Degree of protection of housing to IEC 60 529	IP 20 (when mounted)
	Safety class to EN 60 730	device suited for use with equipment of safety class II
Environmental conditions	Operation to	IEC 60 721-3-3
	Climatic conditions	class 3K5
	Temperature (housing and electronics)	0...50 °C
	Humidity	5...95 % r. h. (noncondensing)
	Mechanical conditions	class 3M2
	Transport to	IEC 60 721-3-2
	Climatic conditions	class 2K3
	Temperature	-25...+70 °C
	Humidity	<95 % r. h.
	Mechanical conditions	class 2M2
Classifications to EN 60 730	Mode of operation, automatic controls	type 1B
	Degree of contamination, controls' environment	2
	Software class	A
	Rated surge voltage	4000 V
	Temperature for ball-pressure test of housing	125 °C
Materials and colors	Terminal base	Polycarbonate, RAL 7035 (light-grey)
	Insert	Polycarbonate, RAL 7035 (light-grey)
	Packaging	corrugated cardboard
Norms and standards	Product safety	
	Automatic electrical controls for household and similar use	EN 60 730-1
	Special requirements for energy controllers	EN 60 730-2-11
	Home and Building Electronic System (HBES)	EN 50 090-2-2
	Electromagnetic compatibility	
	Immunity industrial sector	EN 61 000-6-2
	Emissions domestic sector, light industry	EN 61 000-6-3
	Home and Building Electronic System (HBES)	EN 50 090-2-2
	 conformity to	
	EMC directive	89/336/EEC
Low-voltage directive	73/23/EEC	
 conformity to		
Australian EMC Framework	Radio communication act 1992	
Radio Interference Emission Standard	AS/NZS 3548	
Weight	Excl. packaging	0.49 kg

Connection diagrams

Internal diagrams

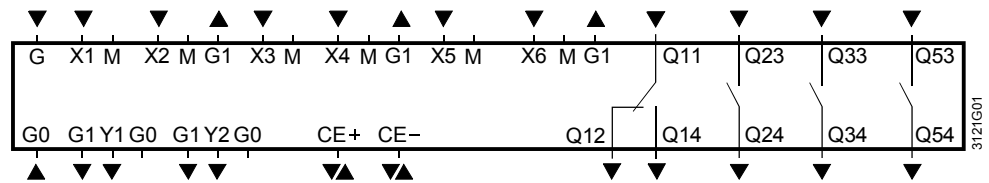

Legend

G, G0	Rated voltage AC 24 V
G1	Output voltage AC 24 V for powering external active units
M	Measuring neutral for signal input
G0	System neutral for signal output
X1...X6	Universal signal inputs for LG-Ni 1000, 2x LG-Ni 1000 (averaging), T1, Pt 1000, DC 0...10 V, contact sensing (potential-free)
Y1...Y2	Control or status outputs, analog DC 0...10 V
Q...	Potential-free relay outputs for AC 24...230 V
CE+	Konnex bus data line, positive
CE-	Konnex bus data line, negative

Notes

Each terminal (spring cage terminal) can only accommodate 1 solid wire or 1 stranded wire. Double terminals are internally interconnected.

Connection diagrams

Connections on the measuring side

Examples:

Connection diagram 1: Measuring section with passive sensor

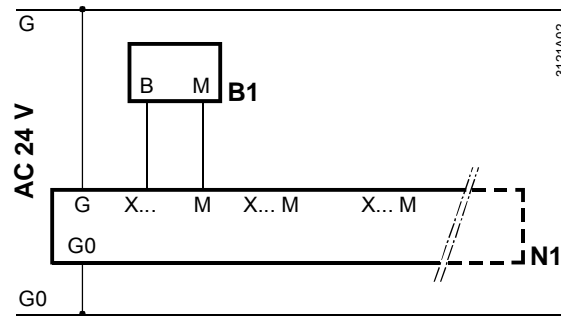

Connection diagram 2: Measuring section with active sensor

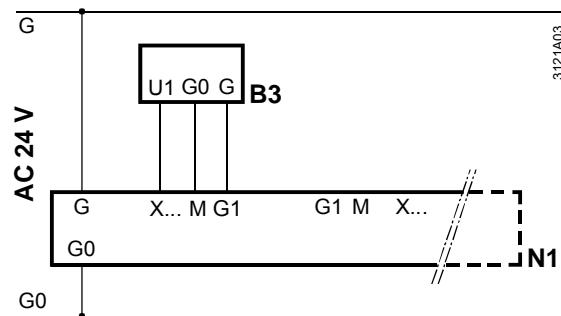

Connections on the control and monitoring side

Connection diagram 3: Multiple use of sensors (B1, N2) and output of the resulting operating mode of a room group to other devices (N3) – required for internal configuration, refer to the Basic Documentation CE1P3121en – "Digital input" (S6)

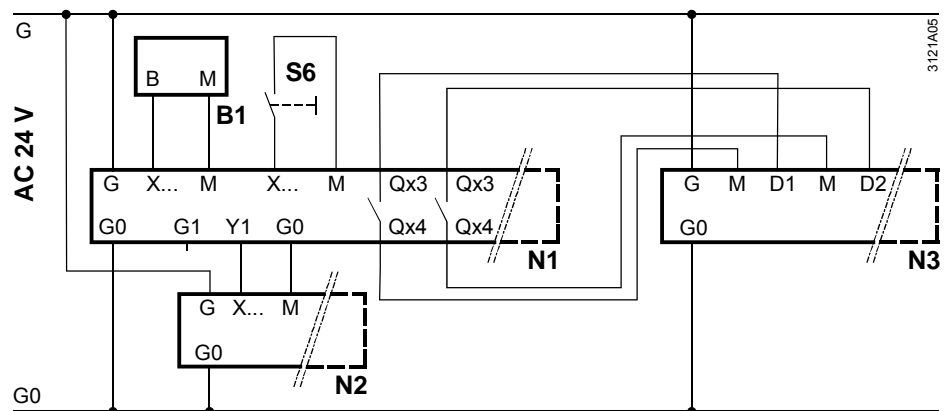

Legend to the connection diagrams 1 through 3

N1 Central control unit RMB795
N2 Universal controller RLU210
N3 Universal controller RLU232

B1 Duct temperature sensor QAM21.20...
B3 Duct temperature sensor QAM2161.040
S6 Heating / cooling changeover switch

