



**QAF63.2**  
**QAF63.6**

## Frost sensors

for use on the air side

- Active capillary tube sensor for measuring the lowest temperature within a range of 0...15 °C
- Operating voltage AC 24 V
- Signal output DC 0...10 V

### Use

On the air side of ventilating and air conditioning plants:

- Typically: hot water air heating coils where there is a risk of freezing due to cold incoming outside air
- Where fans are to be switched off, heating valves opened, air dampers closed or other actions need to be taken by the control system to prevent freeze-ups

### Type summary

Type reference	Description
<b>QAF63.2</b>	Frost sensor with <b>6 m</b> capillary
<b>QAF63.6</b>	Frost sensor with <b>6 m</b> capillary

## Accessories

Included in the scope of delivery

- 1 x Pg 11 cable gland for cable entry
- 2 x Screw to DIN 7981-St 4.2 x 22 for direct mounting
- 1 x Rubber grommet for capillary entries into air ducts (**4 109 2106 0**)

Not included in the scope of delivery

Type reference	Description	Parts
<b>AQM63.0</b>	Mounting flange	1 x depth-adjustable LG mounting flange for the housing
<b>AQM63.2</b> <sup>1)</sup>	Capillary supports	3 x capillary tube clamp 3 x spacer

1) The **QAF63.6** requires two **AQM63.2**

## Ordering and delivery

When ordering, please give name and type reference, e.g. frost sensor **QAF63.2**.

The mounting accessories not included in the scope of delivery must be ordered as separate items.

## Technical design

With the help of a vapour-filled capillary and diaphragm, the QAF63... acquires the lowest temperature which occurs along at least 250 mm length of capillary tubing.

If the frost sensor is correctly located at the air outlet of the air heating coil, it acquires the lowest air temperature even in the case of temperature stratification. The vapour pressure in the capillary tube produces a certain travel of the diaphragm. This movement is converted to an electric signal with the help of an inductive measuring system; it is then electronically amplified so that a DC 0...10 V measuring signal can be produced (terminal B).

To make certain it is always the lowest temperature along the capillary that is measured, the temperature of the diaphragm inside the housing must always be higher than the temperature at the capillary tube. This is ensured by a heating element fitted inside the housing, which maintains the temperature at the diaphragm above 15 °C as long as the ambient temperature does not fall below -15 °C.

## Mechanical design

The frost sensor consists of a two-sectional housing - base and cover - and a capillary tube which is active over its full length.

The cover is secured to the base with a fixing screw and can be removed.

The housing accommodates the electronics, the diaphragm with the heating element, the connection terminals and the type field.

Connection terminals and type field can be accessed after removing the cover.

The cables are introduced to the housing from below. There is one hole for the enclosed cable gland Pg11, and two knockout holes for additional cable glands Pg 11.

The QFA63... can be fitted directly to the wall - with or without a test loop - or with the help of a mounting flange (if the air duct is insulated).

## Engineering notes

---

The frost sensor operates on AC 24 V. The transformer used must be suitable for safety extra low voltage (SELV), 100 % duty, and must have separate windings.

Fuses, switches, wiring and earthing must be in compliance with local safety regulations. The permissible cable lengths must be observed.

If the capillary is mechanically damaged or if there is a leak in the diaphragm system, the detector signals a temperature of 0 °C. That is the case also if there is a power failure or if one of the major electronic components fails.

## Fitting notes

---

### Mounting location

On the hot side of the air heating coil.

### Mounting of housing

#### Direct mounting

Fit the housing (by using the two fixing holes) to the wall of the air heating coil. Introduce the capillary tube in the air duct and protect it by using the rubber grommet supplied with the sensor (refer to "Accessories").

When fitting the sensor inside the air duct: secure the housing to the inner wall of the air heating coil and lead the capillary tube through one of the lateral grooves.

#### Direct mounting, with test loop for functional test

Fit the housing (by using the two fixing holes) to the wall of the air heating coil and lead the capillary tube through one of the lateral grooves.

Bend the capillary to form a test loop, introduce the capillary to the air duct and protect it by using the enclosed rubber grommet (refer to "Accessories").

This mounting method is not recommended when the ambient temperature at the external test loop may fall below the temperature at the measuring location in the air duct (the measuring signal of the detector always represents the lowest temperature, no matter where it occurs along the capillary tube!).

#### With LG mounting flange (refer to "Accessories")

This mounting method is suited for air ducts having an insulation of up to 70 mm.

Fit the mounting flange to the wall of the air heating coil and introduce the capillary tube through the flange in the air duct.

### Fitting the capillary tube

Coil the capillary tube evenly across the entire cross-sectional area of the air heating coil and attach it to the coil with the help of the clamps, maintaining a spacing of 40 mm (refer to "Accessories").

#### Note!

The capillary tube must not be sharply bent. The bending radius should be as great as possible.

## Installation notes

---

The connection terminals are protected against wiring errors with own voltages up to AC 24 V.

## Commissioning notes

---

There are no settings required on the frost sensor.

Using a test loop, the proper functioning of the frost detector can be checked with the help of a mixture of ice and water.

## Technical data

Power supply	Operating voltage (SELV)	AC 24 V $\pm$ 20 %
	Frequency	50/60 Hz
	Power consumption	5 VA
	At ambient temperatures >10 °C (with no heating)	2.5 VA
Line lengths for the measuring signal terminal B - M	Perm. cable length	
	Copper cable 1.5 mm <sup>2</sup>	300 m
Functional data	Measuring range	0...15 °C
	Time constant	
	In still air	approx. 90 s
	In moving air	<40 s
	Output signal, linear (terminal B)	DC 0...10 V $\hat{=}$ 0...15 °C $\pm$ 1 mA max.
Capillary tube	Min. active length	250 mm
	Perm. temperature	110 °C max.
	Degree of protection of housing	IP 42 to EN 60 529
Protective data	Safety class	III to EN 60 730
Electrical connections	Screw terminals for	2 x 1.5 mm <sup>2</sup> or 1 x 2.5 mm <sup>2</sup>
	Cable entry	Pg 11 cable gland
Environmental conditions	Operation to	IEC 721-3-3
	Climatic conditions	
	Temperature	-15...+60 °C
	Humidity	<85 % r. H.
	Storage/transport to	IEC 721-3-2
Climatic conditions	class 2K3	
Temperature	-25...+65 °C	
Humidity	<95 % r. H.	
Mechanical conditions	class 2M2	
Materials and colors	Housing base	Wellamid 6600 HWC8, RAL 7001 (silver-grey)
	Housing cover	PC Lexan 161R, transparent
	Mounting flange	PA 66, black
	Capillary tube	copper
	Packaging	corrugated cardboard
Norms and standards	Product standards	
	Automatic electrical controls for household and similar use	EN 60 730
	Electromagnetic compatibility	
	Emissions	EN 50 081-1
Immunity	EN 50 082-2	
<b>CE</b> conformity to EMC directive	89/336/EEC	
Weight	QAF63.2	approx. 0.32 kg
	QAF63.6	approx. 0.39 kg

**Internal diagram**

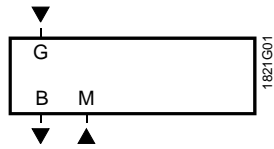

- G System voltage (SELV) AC 24 V
- M System neutral, measuring neutral
- B Signal output DC 0...10 V  $\hat{=}$  0...15 °C

**Dimensions (dimensions in mm)**

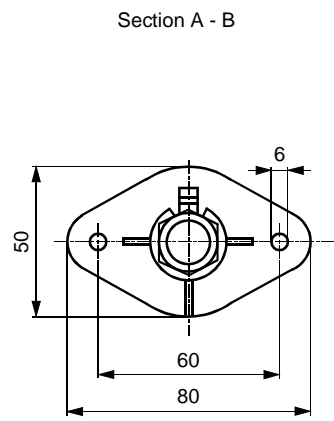
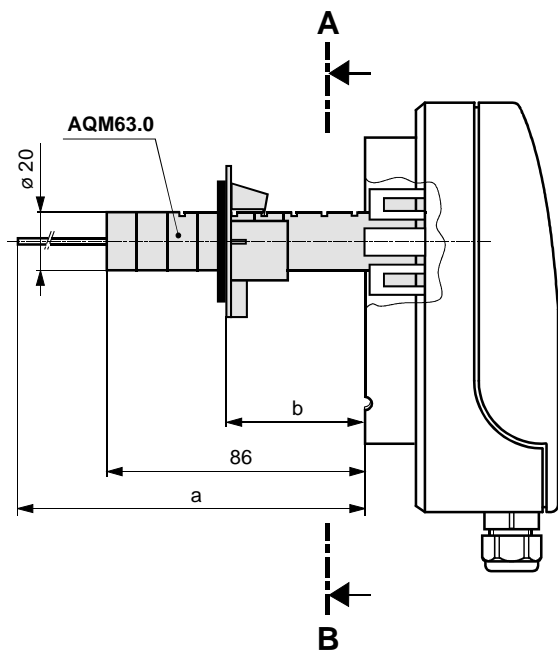
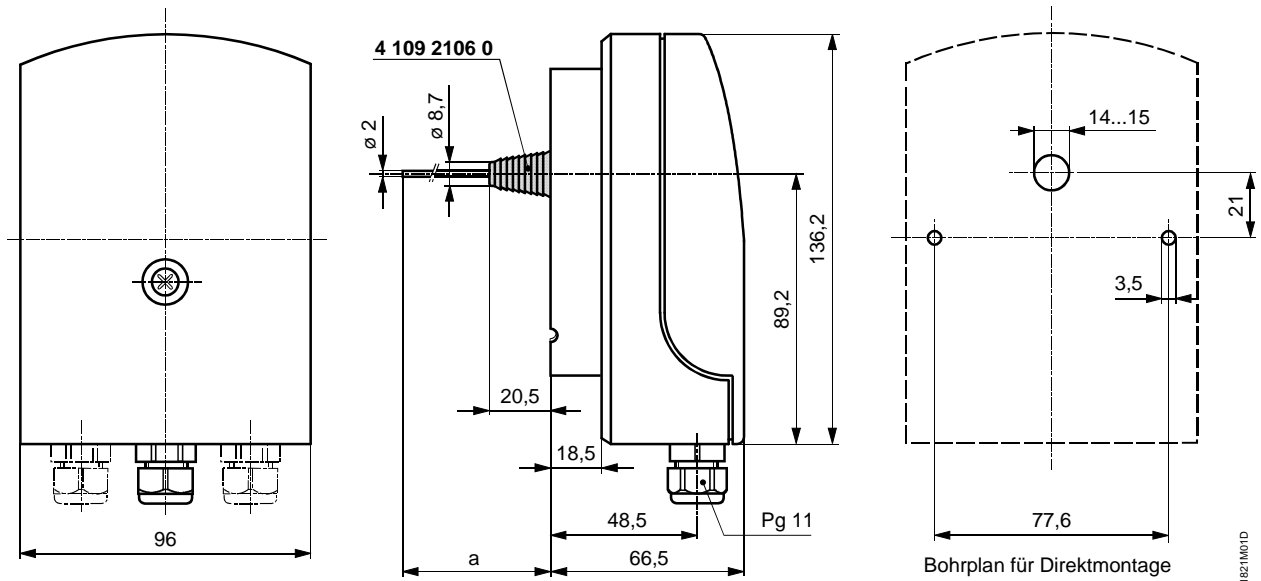

Type	a	b	
		max.	min.
QAF63.2	2000	70	10
QAF63.6	6000	70	10

QAF63... with depth-adjustable mounting flange AQM63.0

